

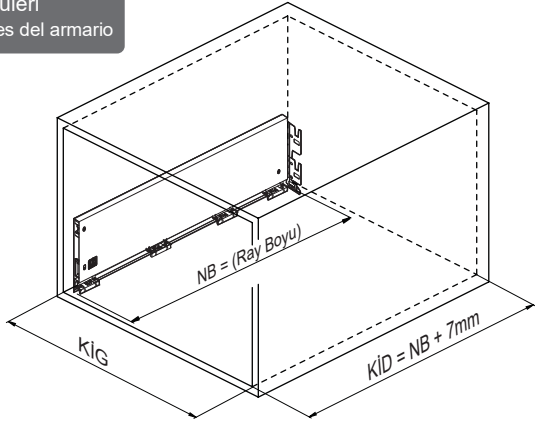

Kabin Ölçüleri Dimensiones del armario



Rayların Vida Konum Ölçüleri Ubicación de los tornillos para las correderas

Rayı işaretlenmiş deliklerden vidalayınız.
Atornille la corredera en los agujeros marcados.

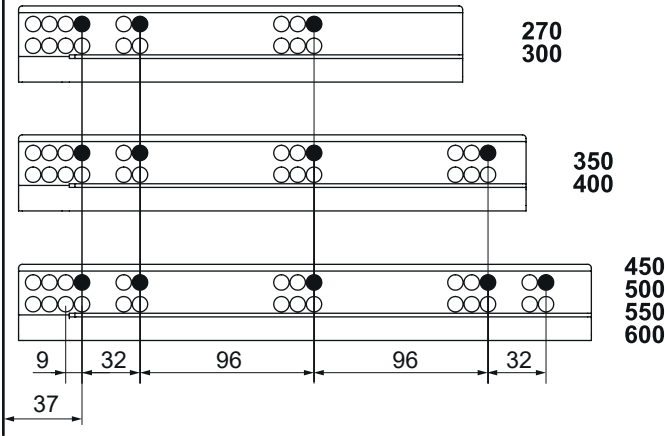

Bas - Aç Ray Ayarı Ajuste para corredera con apertura a presión

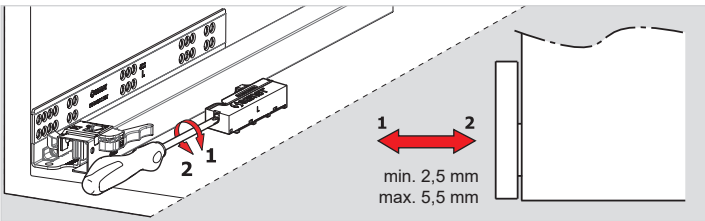

Ön Panel Panel delantero

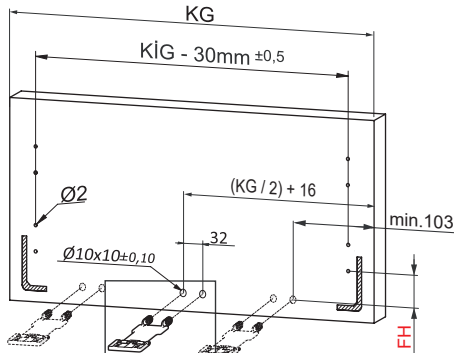

KIG ≥ 600mm

	16 mm Taban Tahtası Suelo de madera de 16 mm	18 mm Taban Tahtası Suelo de madera de 18 mm
FH	25	27

KIG : Kabin İç Genişliği
KID : Kabin İç Derinliği
NB : Nominal Boy
KG : Ön Panel Genişliği
B : Klapa Yan Binisi
X : Klapa Alt Binisi

AIA: Ancho interior del armario
PIA: Profundidad interior del armario
LN: Longitud nominal
KG: Ancho del panel delantero
B: Superposición lateral del panel delantero
X: Superposición lateral del panel inferior

Tavsiye Edilen Vida ve Şablonlar Plantillas y tornillos recomendados



Gövdede Yer İhtiyacı Dimensiones de montaje de corredera

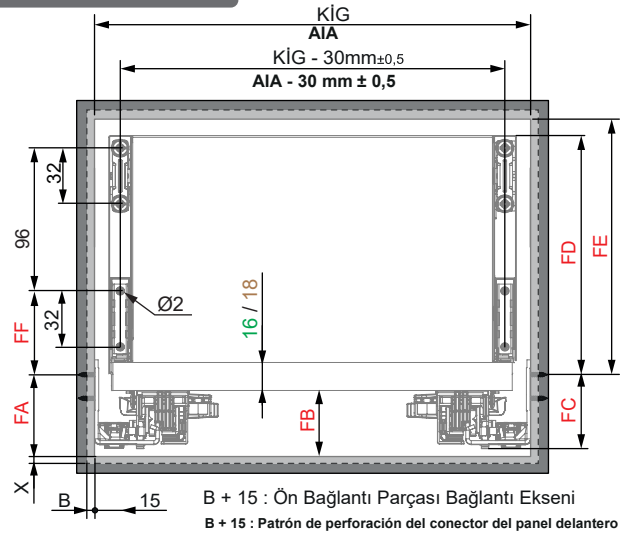

B + 15 : Ön Bağlantı Parçası Bağlantı Eksenini
B + 15 : Patrón de perforación del conector del panel delantero

16 mm Taban Tahtası Uygulaması Aplicación de suelo de madera de 16 mm				
	SC		PO - YBA	
	H.192	H.256	H.192	H.256
FA	41		43	
FB	34		36	
FC	39		42	
FD	153	185	153	185
FE	157	189	157	189
FF	50		50	

18 mm Taban Tahtası Uygulaması Aplicación de suelo de madera de 18 mm				
	SC		PO - YBA	
	H.192	H.256	H.192	H.256
FA	41		43	
FB	34		36	
FC	39		42	
FD	155	187	155	187
FE	159	191	159	191
FF	52		52	

CS: Corredera de cierre suave / Yavaşlatıcı Ray
AP: Corredera de apertura a presión / Bas-Aç Ray
YBA : Corredera de cierre suave y apertura a presión / Yavaşlatıcı Bas-Aç Ray

Ahşap Çekmece Tabanı Suelo de cajón de madera

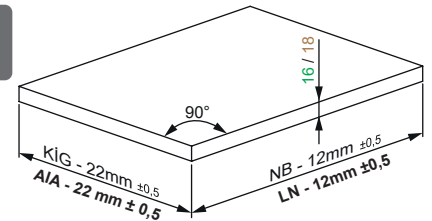

Ahşap Arkalık Respaldo de madera

	H.192	H.256
FG	144	208

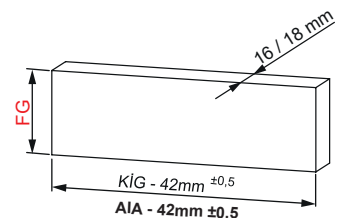



Montaj / Montaje

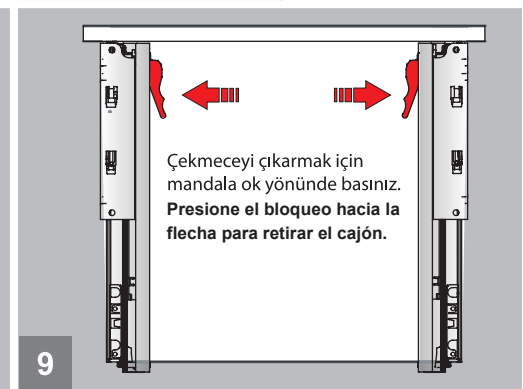
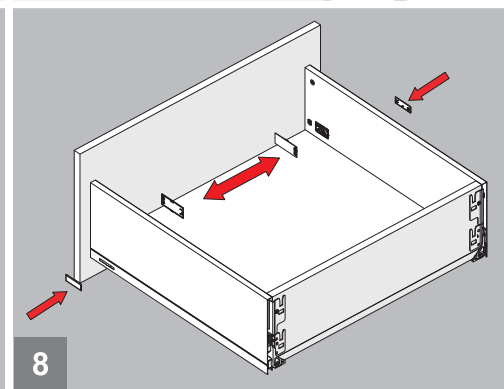
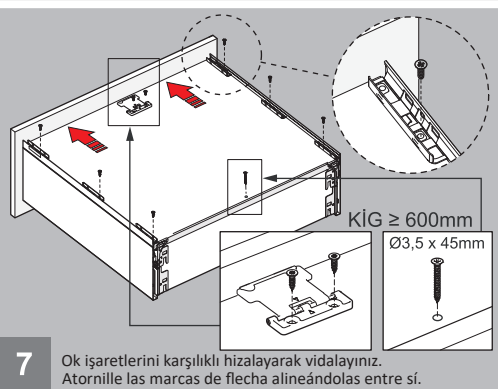
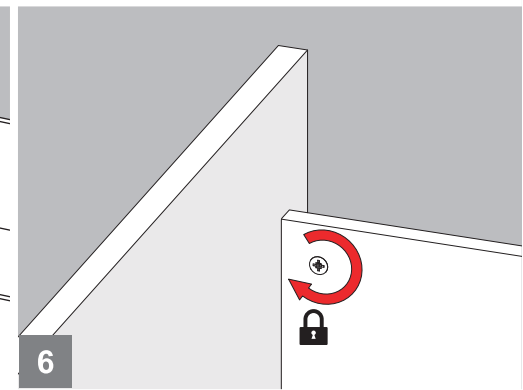
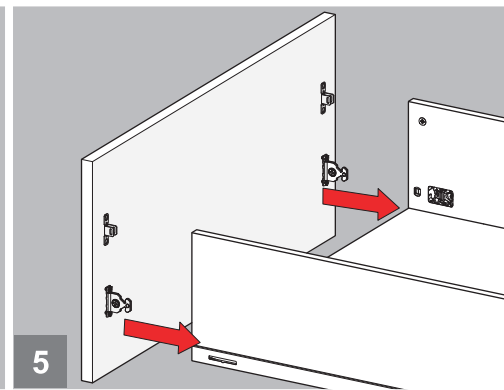
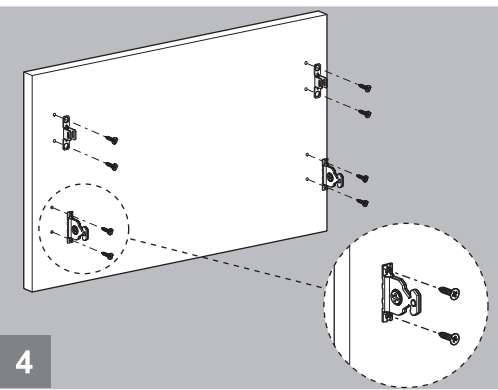
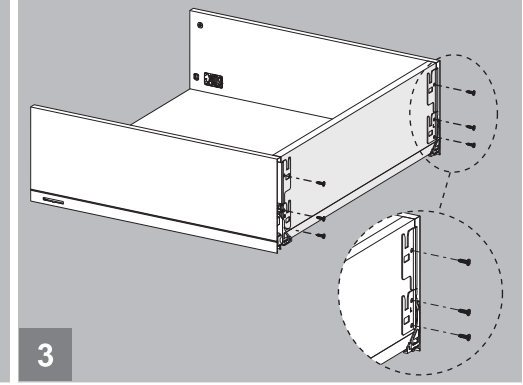
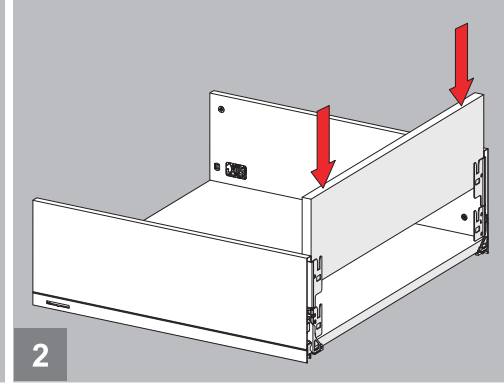
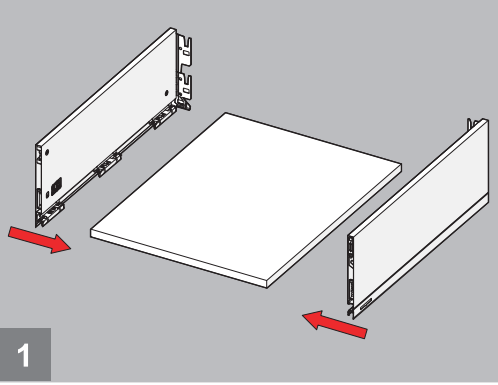

Ayar / Ajuste

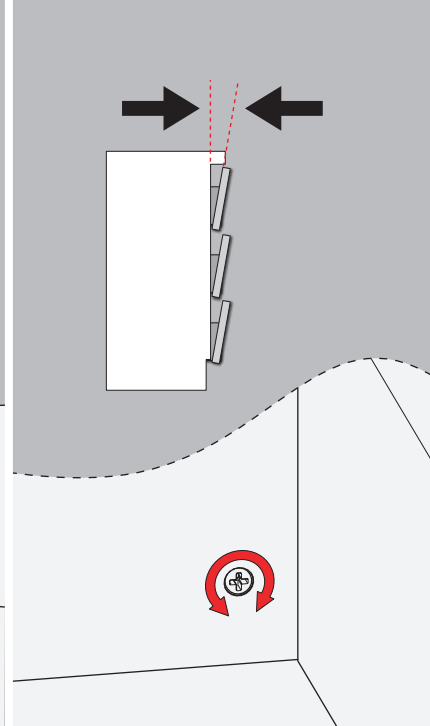
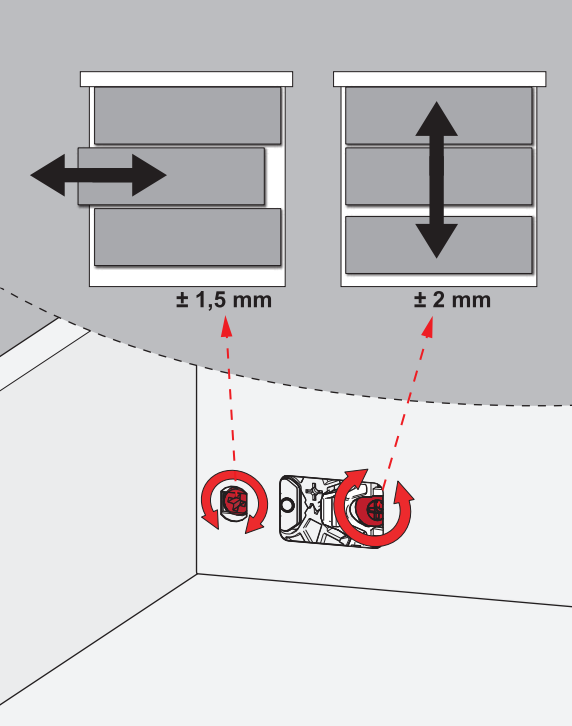

Önemli / Importante

