

SMARTBOX

samet

Çekmece Sistemleri Kullanım Kılavuzu

Handbuch für Schubladensysteme

Schubkastensysteme Gebrauchsanleitung

Руководство по эксплуатации Выдвижных Систем

抽屜系統指南

Mode d'emploi du tiroir

Manuel de cajones

Manuale per l'uso dei sistemi per cassetto

Manual for skuffsystem

서랍계통매뉴얼

Manual för lådsystem

Instrukcja systemów szuflad

Brugervejledning til skuffesystem

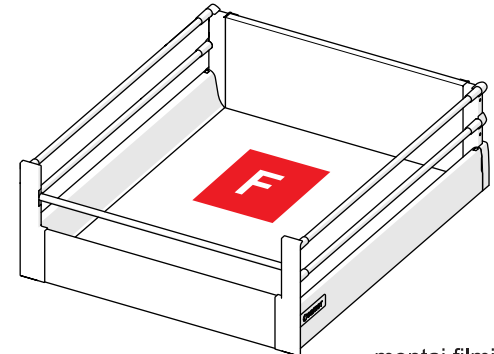
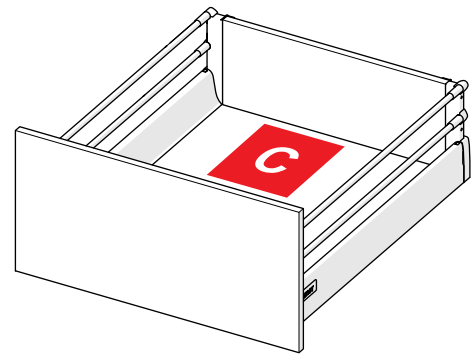
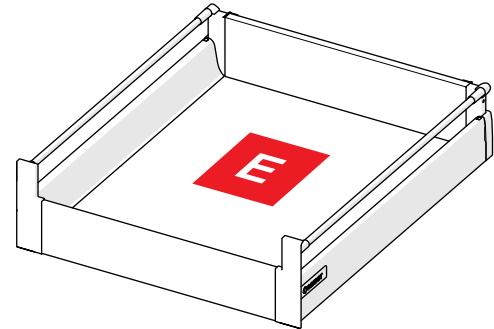
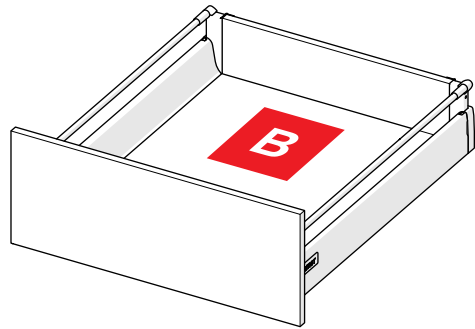
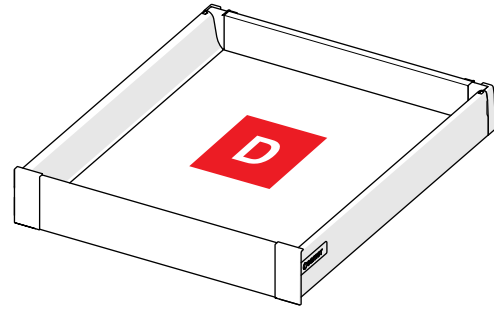
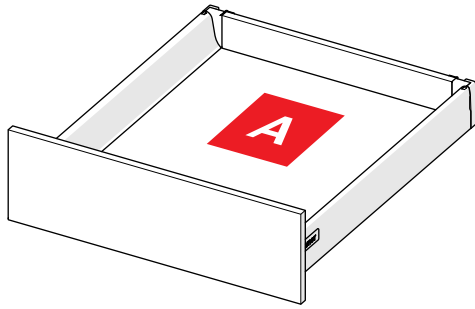

montaj filmi
montagevideo
montagefilm
видео для монтажа
安裝視頻

film de montage
video de montage
video del montaggio
monteringsvideo
조립비디오

monteringsvideo
instrukcja wideo montażu
instruktionsvideo

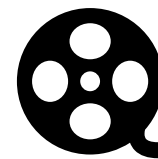

www.samet.com.tr/video/



LGAI

cabinet vision
www.cabinetvision.com



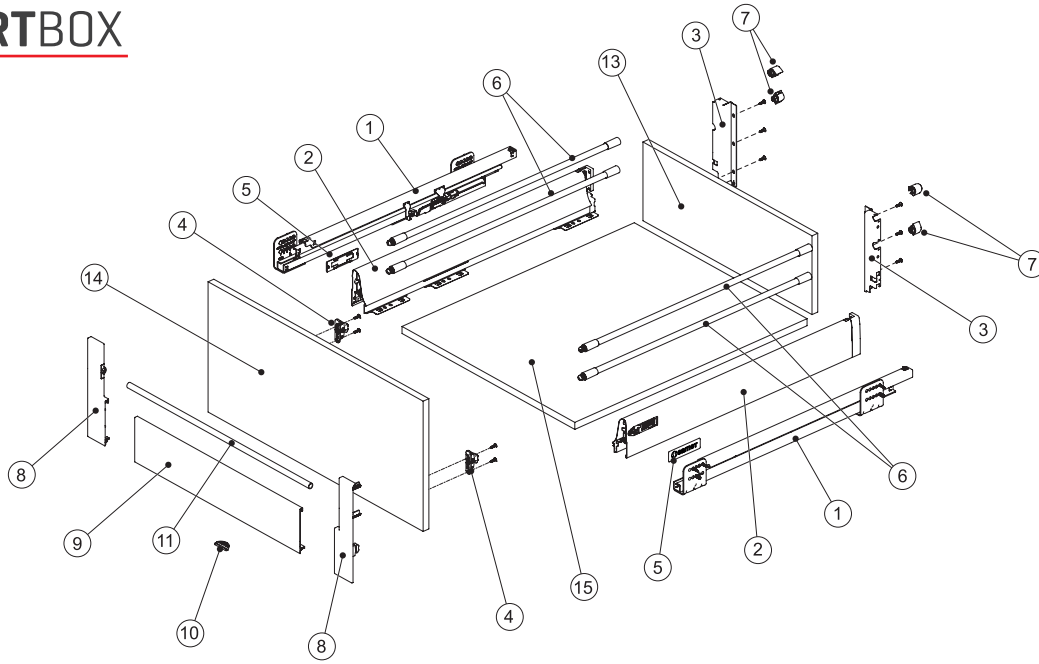

Temel Paket Parçaları / Hauptkomponenten des Pakets / Hauptkomponenten des Pakets / 主要的封装组件 / Hovedpakkens komponenter / Composants du paquet principal / Componentes principales del envase / Komponenter i huvudpaket / Componenti del pacchetto principale / 주요 패키지 구성 요소 / Elementy głównego pakietu / Hovedemballasjekomponenter / Компоненты основного пакета

Ray
Schiene
Führung
Направляющие
滑軌
La coulisse
Guia
Guide
Renne
슬라이드
Glidlist
Prowadnica
Glideskinne

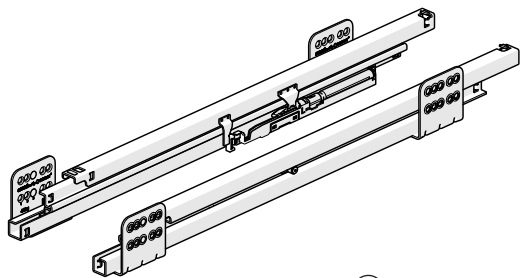

①
A - B - C - D - E - F

Yanak Sacı
Seitenwand
Zarge
Боковины
側板
Le côté de tiroir
Chapa lateral
Spondina laterale
Sidepanel
옆판
Sidopanel
Panel boczny
Sidedel

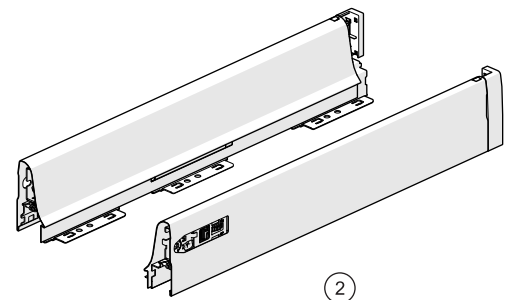

②
A - B - C - D - E - F

Arkalık Tutucu
Rückwandhalter
Rückwandhalter
Крепления задней панели
背板固定器
La Fixation du dos
Soporte trasero
Sostegno del pannello posteriore
Bakbordholder
백보드 홀더
Hållare baksida
Uchwyty płyty tylnej
Holder til bagplade

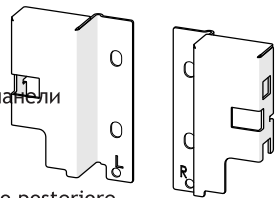

③
A - D

Ön Bağlantı Elemanı
Frontbefestigung
Frontverbinder
Крепления фасада
前连接部件
Le connecteur de la façade
Pieza para fijacion frontal
Componente di fissaggio pannello frontale
Forbindelsesdel foran
앞연결피이스스
Anslutningsdelar för front
Przednie elementy połączeniowe
Forbindelsesdele til fronten

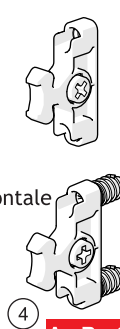

④
A - B - C

Süs Kapağı
Verkleidung
Abdeckkappe
Декоративные заглушки
裝飾标签
Le cache
Tapa decorativa
Copriregolazione laterale personalizzabile
Dekorativt deksel
장식커버
Dekorkåpa
Ostona dekoracyjna
Dekorativ afdækning

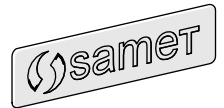

⑤
A - B - C - D - E - F

Bordürlü Uygulama Aksesuarları / Zubehör für Galeriestäbe-Anwendung / Zubehör für Stollen-Geländereinsatz / 栏杆图库应用的配件 / Tilbehør til påsætning af gelænder / Accessoires pour applications avec des bordures / Aplicación de accesorios de baranda de galería / Tillbehör för montering av sidostänger / Accessori per applicazioni con bordature / 난간 갤러리 어플리케이션 구성품 / Akcesoria do zastosowania z szyną galerii / Tilbehør for gallerirekkverkapplikasjoner / Аксессуары для бордюрной системы

Bordür Grubu
Relinggruppe
Relinggruppe
Рейлинги
护杆组合
Tube / Rambarde
Varillas
Gruppo ringhiera
Gruppe for gallerirekkverk
난간갤러리
Sidostänger
Grupa poręczy galerii
Sideskinnegruppe til galleriet

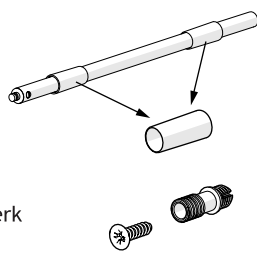

⑥
B - C - E - F

Bordür Tutucular
Relinggruppen-Halter
Relinghalter
Крепления рейлингов
护杆固定器
Le support
Piezas de conexion de las varillas
Sostegni per ringhiera
Holdere for gallerirekkverk
난간갤러리홀더
Hållare sidostänger
Uchwyty poręczy galerii
Holdere til galleriets sideskinne

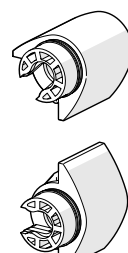

⑦
B - C - E - F

Arkalık Tutucular
Rückwandhalter
Rückwandhalter
Крепления задней панели
背板固定器
La Fixation du dos
Soportes traseros
Sostegni del pannello posteriore
Holdere for bakbrett
뒤판홀더
Hållare baksida
Uchwyty płyty tylnej
Holdere til bagpladen

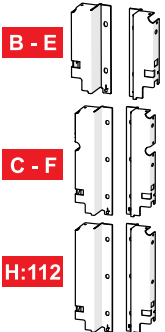

③
B - E
C - F
H:112

İç Çekmece Aksesuarları / Zubehör für Einlege-Schubladen / Zubehör für Schubladen-Innere / 盒内抽屉配件 / Boksskuffetilbehør / Accessoires internes pour tiroirs / Accesorios interiores de gaveta / In-Box lådtillbehør / Accessori interni per cassetti / 인 박스 액세서리 / Akcesoria do szuflady w pudełku / In-Box Darwer tilbehør / Аксессуары выдвижного ящика

Ön Panel Tutucu
Frontbefestigungen
Frontbesfestigung
Крепления передней панели
前连接部件
La fixation de la face
Piezas para fijación frontal
Sostegni pannello frontale
Forbindelsesdel foran
앞 접속부분
Anslutningsdelar för front
Przednie części połączeniowe
Forbindelsesdele til fronten

8

D

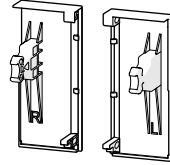

E

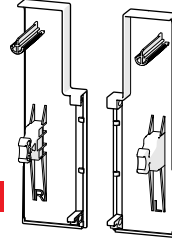

F

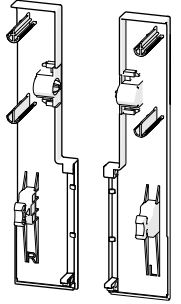

Ön Panel
Frontblende
Frontblende
Передняя панель
前面板
La Facade
Panel frontal
Pannello frontale
Frontpanel
앞패널
Frontpanel
Panel przedni
Fronten

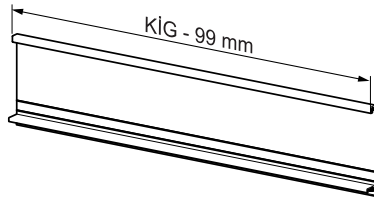

9

D - E - F

Ön Panel Sabitleyici
Frontblendenhalter
Stabilisator für Frontblende
Фиксатор передней панели
前面板固定器
Pièce de Renforcement
Soporte para perfil frontal
Componente di fissaggio pannello frontale
Holder for frontpanel
앞 패널홀더
Hållare frontpanel
Uchwyt panelu przedniego
Holdere til fronten

KIG ≥ 600mm

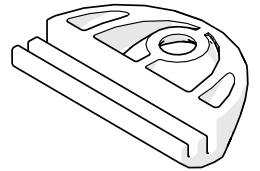

10

D - E - F

Sac Vidası
Blechschaube
Blechschaube
Саморез
塑板螺钉
La vis Parker
Tornillo de chapa
Vite di fissaggio
Skruemark
시트스크루
Plåtskruv
Wkręt arkusza
Pladeskrue

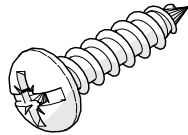

SV = Ø3,5 x 16 mm

D - E - F

Ön Bordür Çubuğu
Vordere Rellingstange
Front Reling
Поперечный рейлинг
下护杆
Le Railing Avant
Varilla frontal
Ringhiera frontale
Rekkverkbar for galleri foran
앞난간갤러리
Frontstång
Belka poręczy galerii przedniej
Sideskinne til skuffegalleri

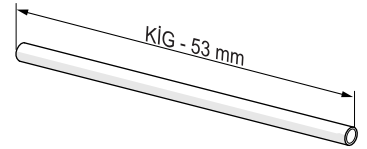

11

F

Yan Yükselticiler / Seitenwände / Seitenwände / 金属背板和侧板 / Sideplader / élévateurs Latéraux / Paneles Laterales / Baksida och sidopaneler av metall / Sollevatori Laterali / 금속 백보드 및 사이드 패널 / Piane Boczne / Sidepaneler / боковые панели

Yan Yükseltici
Seitenwand
Seitenwand
侧板
Sideplade
Elévateurs latéraux
Panel lateral
Sidopanel
Sollevatori laterali
사이드 패널
Panel boczny
Sidepanel
Боковая панель

B - E

H:48



C - F

H:112

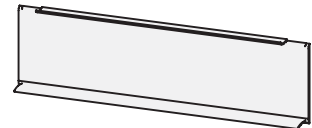

Tavsiye edilir / **Empfohlen** / Empfehlung / Рекомендуем / 推荐 / La recommandation / Recomendacion / Raccomandazione / Anbefalt / 권장 / Rekommanderad / Zalecane / Anbefalet

Vida /Schrauben/ Schraube / Шурупы
螺钉 / La vis / Tornillo
Viti / Skruer / 스크루
Skruv / Wkręt / Skruer



Ø6,1 x 11,5mm



Ø3,5 x 16mm

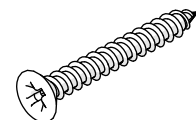

Ø3,5 x 45mm

A - B - C - D - E - F

Kabin, Ahşap Arkalık, Ön Panel ve Ahşap Çekmece Tabanı / Schrank, Holzrückwand, Frontblende und Schubladenboden aus Holz / Gehäuse, Holz-Rückenbrett, Frontplatte und Holz-Schubladenboden / 櫥櫃, 木制背板, 前板和木制地板抽屜 / Kabinet, Bagplade træ, Frontplade og skuffebund af træ / Cabine, Panneau postérieur en bois, Panneau arrière et fond du tiroir bois / Armario, Panel trasero de madera, Panel frontal y Piso de madera de la gaveta / Skåp, Baksida av trä, Frontpanel och lådbotten av trä / Cabina, Pannello posteriore in legno, Pannello anteriore e base del cassetto in legno / 캐비닛, 나무 백보드, 앞쪽 패널과 우드 장판 서랍 / Szafka, Drewniana płyta tylna, Panel przedni i drewniany spód szuflady / Skap, Bakplate i treverk, Frontpanel og treskuffbunn / Кабинка, Деревянная задняя панель, Передняя панель и деревянное основание ящика

KİG = Kabin İç Genişliği
 KIG = Cabinet Internal Width
 KIG = Innenmaß der Kabine
 KIG = Внутренняя ширина каркаса
 KIG = 內箱寬度
 KIG = La dimension intérieure du caisson
 KIG = Medida interior del gabinete
 KIG = Larghezza interna del mobile
 KIG = Bredde internt kabinett
 KIG = 캐비닛안폭
 KIG = Skåpets invändiga bredd
 KIG = Szerokość wewnętrzna szafki
 KIG = Skabets indvendige størrelse

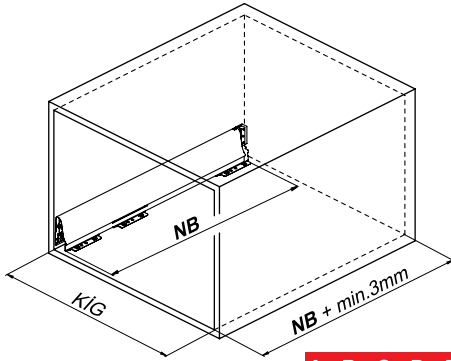

A - B - C - D - E - F

	A - D	B - E	C - F
Z	68mm 2-21/32"	116mm 4-9/16"	180mm 7-2/32"

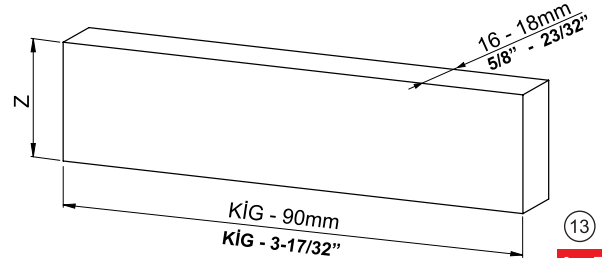

(13)

A - B - C

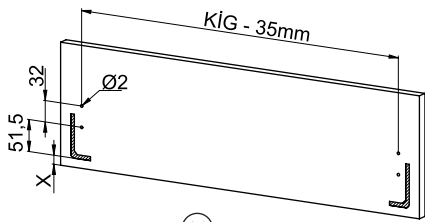
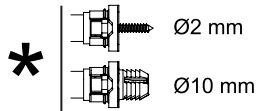

(14)

A

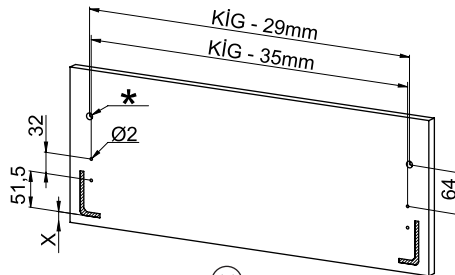

(14)

B

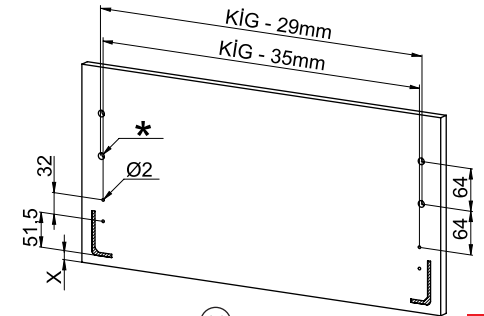

(14)

C

Ahşap Arkalık Uygulamasında / Holzrückwand-Anwendung / Holzrückwandbefestigung / При использовании задней панели из ДСП / 木质背板安装说明 / La fixation du fond bois / Aplicaciones tablero trasero de madera / Applicazione parte posteriore in legno / Applikasjon for trebakkrett / 목재 뒤판 사용 / Fastsättning baksida av trä / Drewniane zdobienie płyty tylnej / Montering af bagplade af træ

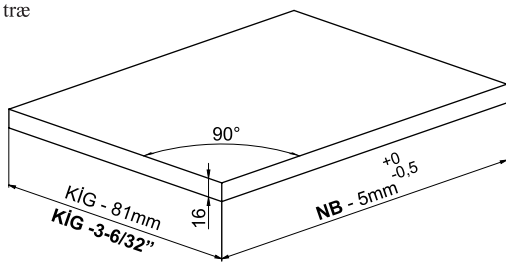

Metal Arkalık Uygulamasında / Metallrückwand-Anwendung / Metallrückwandbefestigung / При использовании металла заднюю панель / 金属背板安装说明 / La fixation du fond métal / Aplicaciones tablero trasero de metal / Applicazione parte posteriore in metallo / Applikasjon for metall / 금속 거울을 사용 / Fastsättning baksida av metall / Metal zdobienie płyty tylnej / Montering af bagplade metal

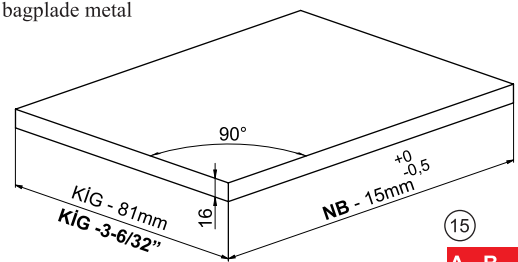

(15)

A - B - C - D - E - F

Çekmece Önü Stabilizatörü / Stabilisator für Schubladen-Frontblende / Stabilisator für Frontblende / Фиксатор передней панели / 抽屜前端固定器 / Le stabilisateur de la facade / Estabilizador para frontal de cajones / Stabilizzatore pannello frontale del cassetto / Stabilisator for frontskuff / 서랍의 앞고정장치 / Förstärkning lådfrent / Stabilizator przedni szuflady / Stabilisator for skuffefrenten

KİG ≥ 600mm

600mm ve daha geniş kabinlerde kullanılır
 Verwendet für 600 mm und breitere Schränke
 Werden mit 600mm und breiteren Gehäuse benutzt
 使用 600 mm 或更宽的櫥櫃
 Bruget sammen med kabinetter på 600 mm og derover
 Utilisé pour des tiroirs de 600 mm et plus larges
 Usado con armarios de 600 mm y más anchos
 Används på skåp 600mm och bredare
 Utilizzato in cabine da 600 mm e più larghe
 600 mm 또는 더 넓은 캐비닛 사용
 Do szafek o szerokości co najmniej 600 mm
 Brukes på skap som er 600 mm eller bredere
 Используется в кабинках 600мм и более

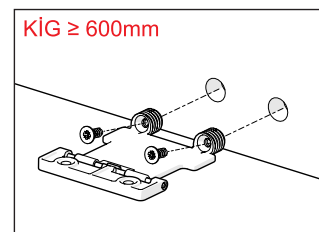
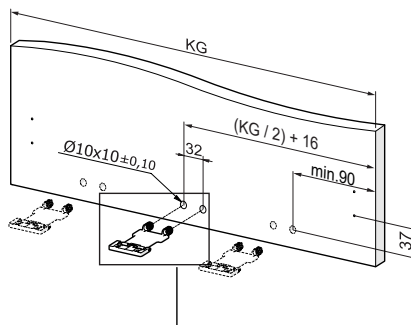

A - B - C

Ray vida konum ölçüleri / Schraubenposition der schienenführungen / Schraubposition / Установка направляющих / 箱体滑轨上螺钉的位置 / Position de la vis de fixation de la coulisse / Las medidas de los puntos de los tornillos para guías / Schema di foratura per viti delle guide / Skruelassering for renner / 스크라이드에서 스크루를 조이는 위치 / Placering av glidlistens skruvar / Umiejscowienie wkrętów prowadnic / Skruelplacering for glideskinnerne

A - B - C

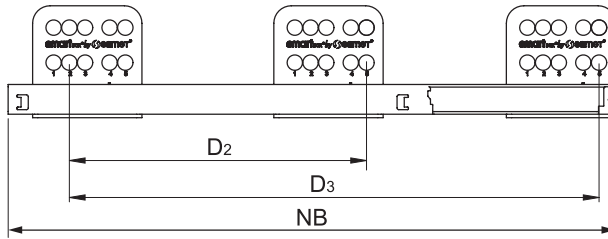
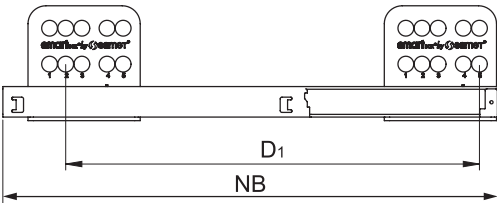
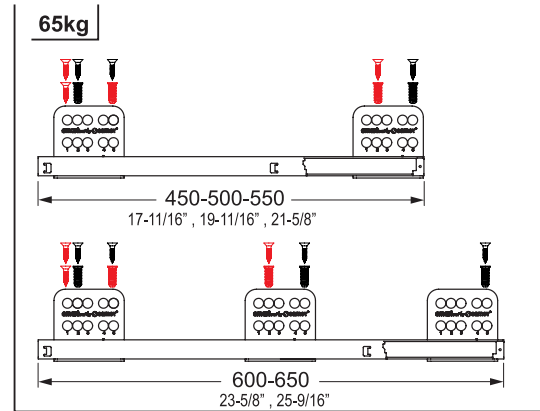
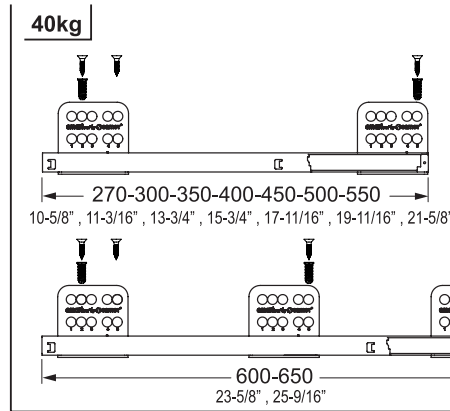
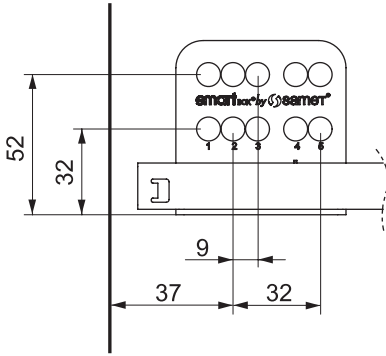

NB	D1	D2	D3
270	224	-	-
300	8-13/16"	-	-
350	288	-	-
400	11-10/32"	-	-
450	352	-	-
500	416	-	-
550	16-12/32"	-	-
600	-	288	480
		11-10/32"	11-14/16"
650	-	320	512
		12-19/32"	20-5/32"

D - E - F

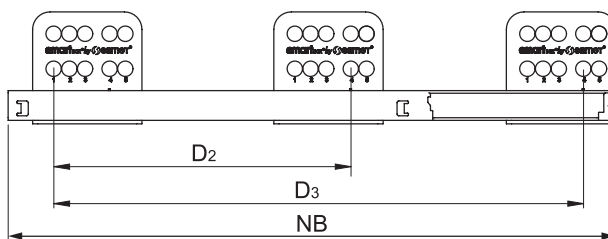
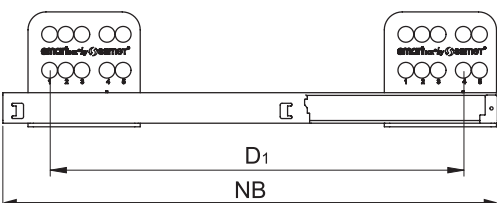
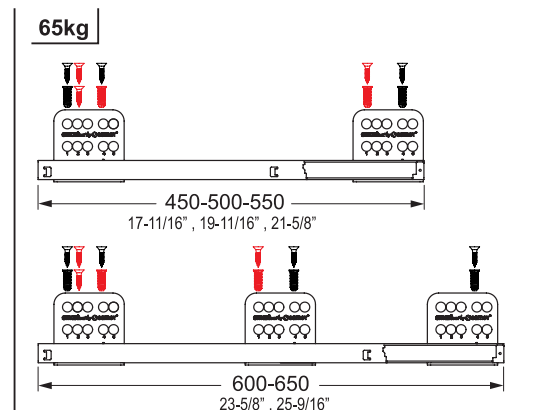
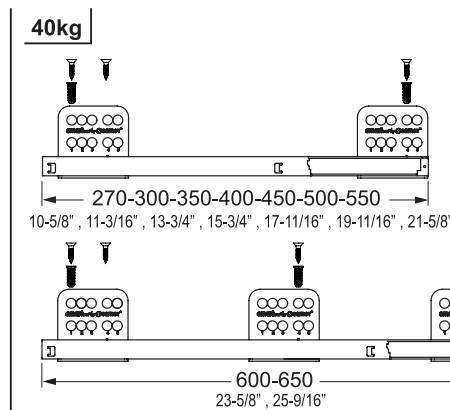
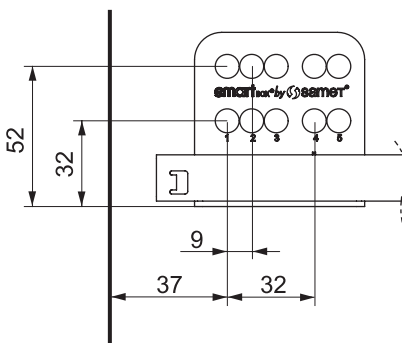

NB	D1	D2	D3
270	224	-	-
300	8-13/16"	-	-
350	288	-	-
400	11-10/32"	-	-
450	352	-	-
500	416	-	-
550	16-12/32"	-	-
600	-	288	480
		11-10/32"	11-14/16"
650	-	320	512
		12-19/32"	20-5/32"

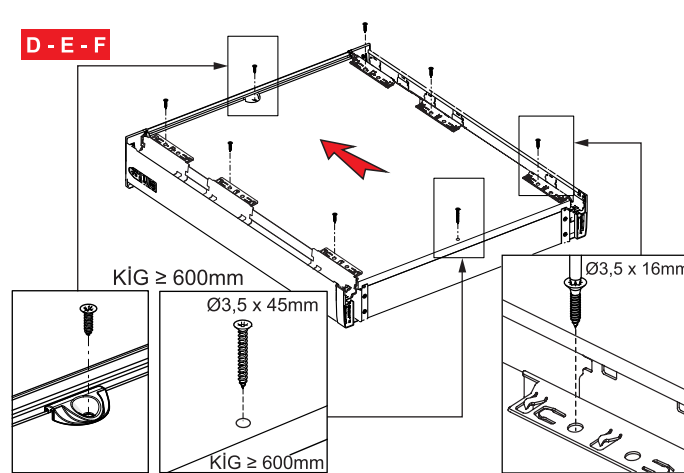
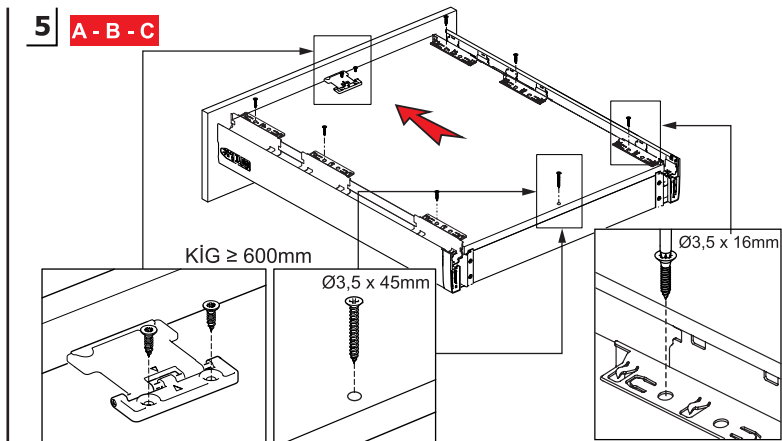
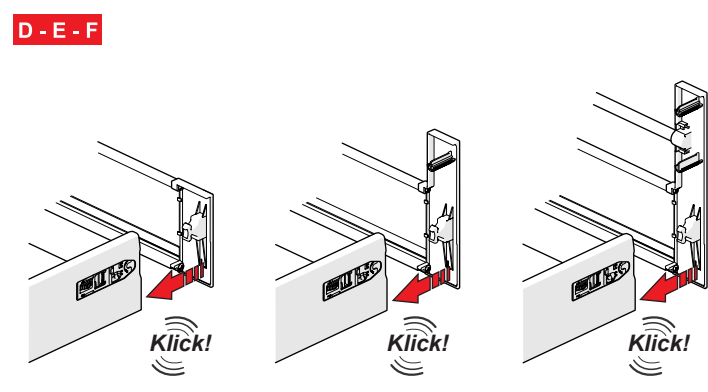
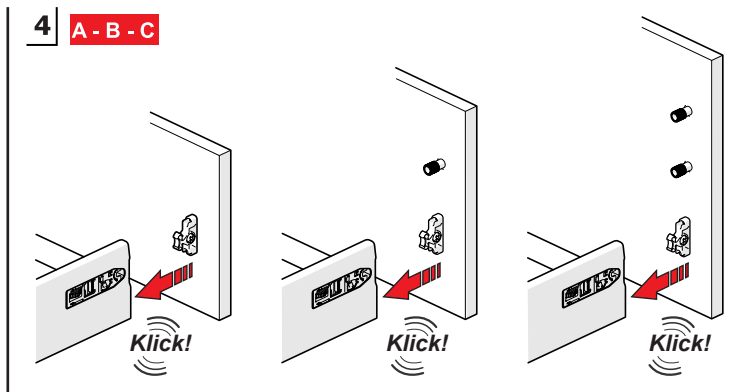
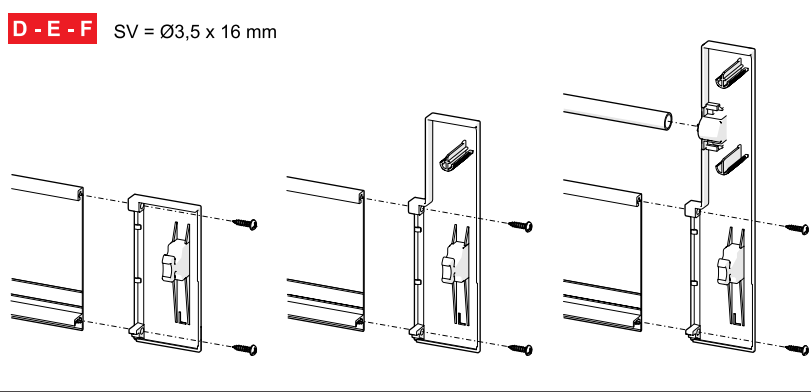
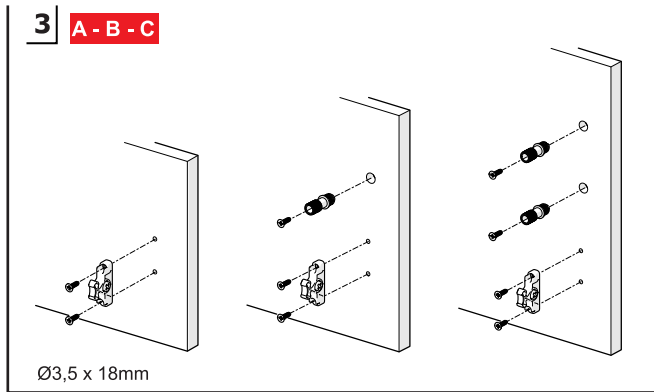
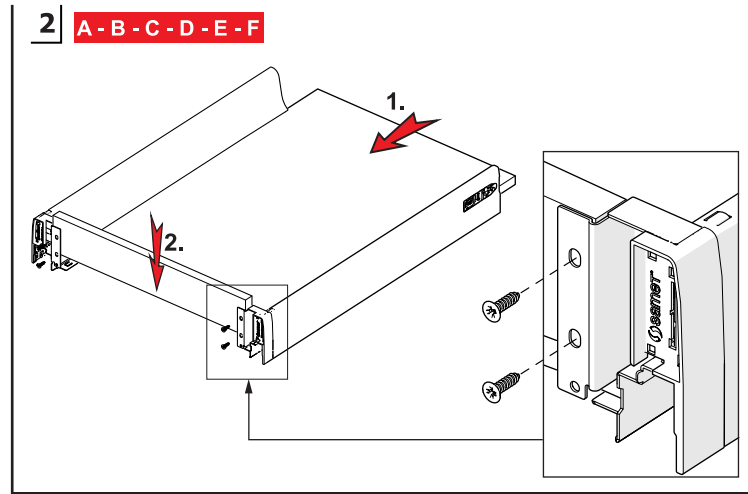
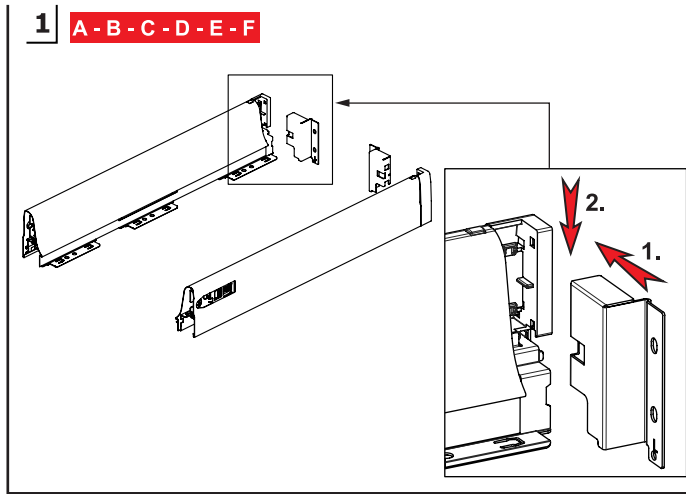

Ok işaretlerini karşılıklı hizalayarak vidalayınız.
In Richtung Pfeilmarkierungen einschrauben, und diese aneinander ausrichten.

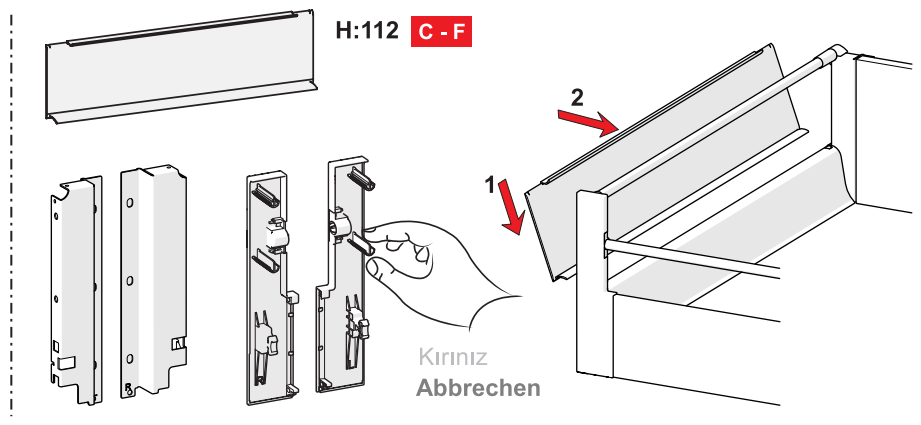
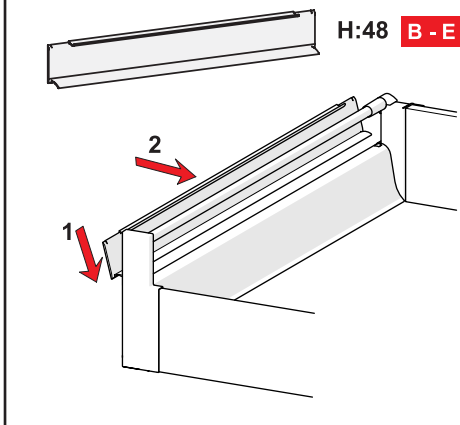
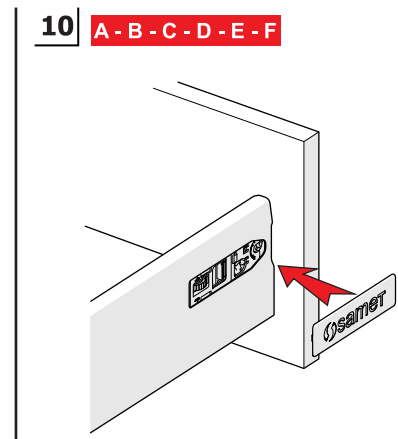
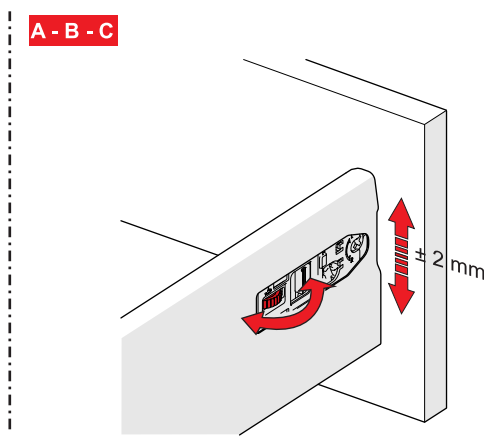
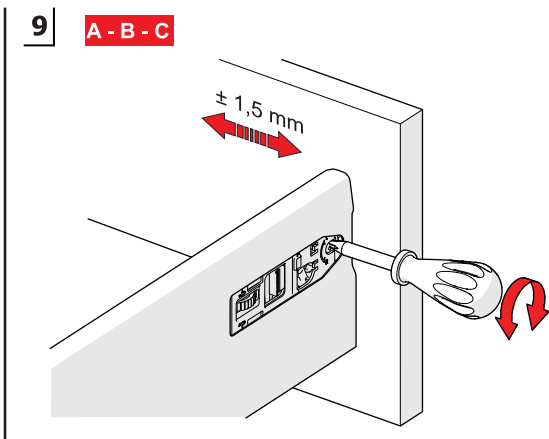
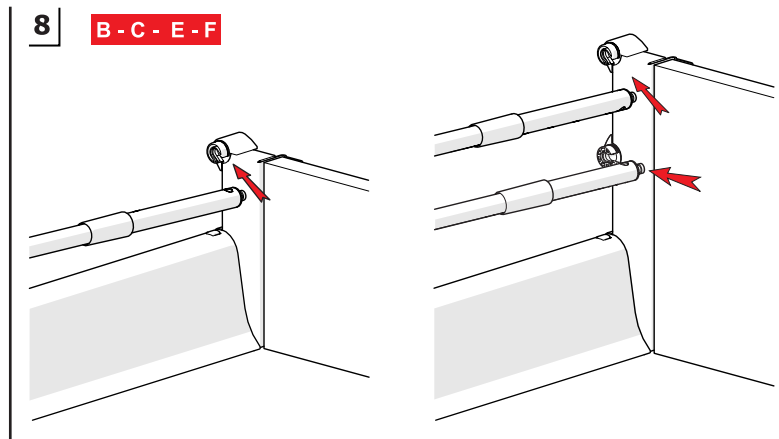
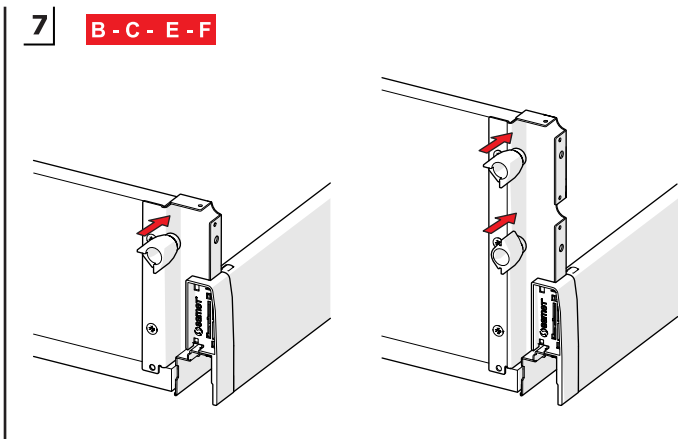
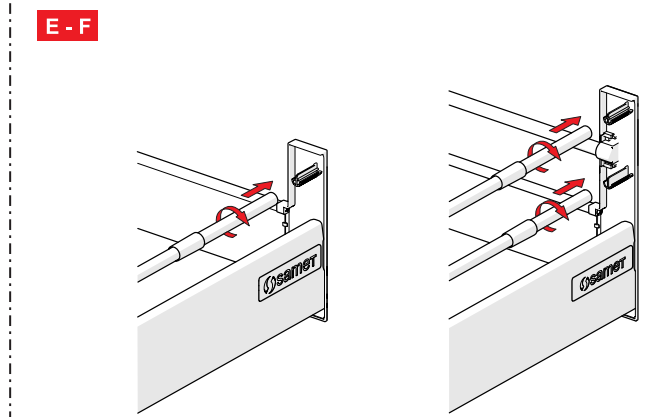
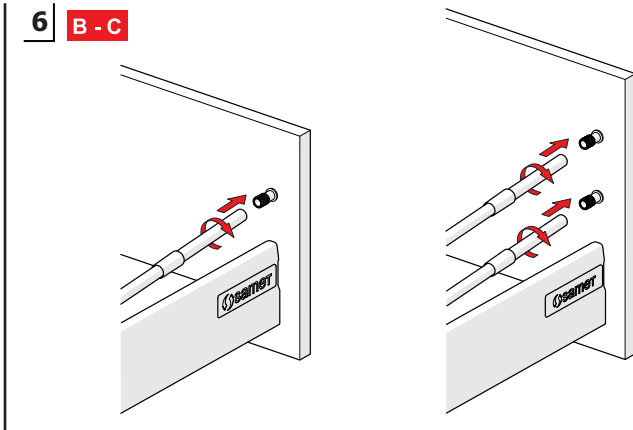

Çekmecenin raya montajı / Montage der Schublade auf die Führungsschienen. / Schubkastenmontage auf die Führung / Установка ящика / 将抽屉安装到滑轨上
 Le montage du tiroir sur la coulisse / El Montaje del cajon a las guias / Montaggio del cassetto sulla guida / Montering av skuff til renne
 슬라이드에 서랍을 설치기 / Montering av lådan på glidlisterna / Montowanie szuflady do prowadnicy / Montering af skufferne på glideskinne

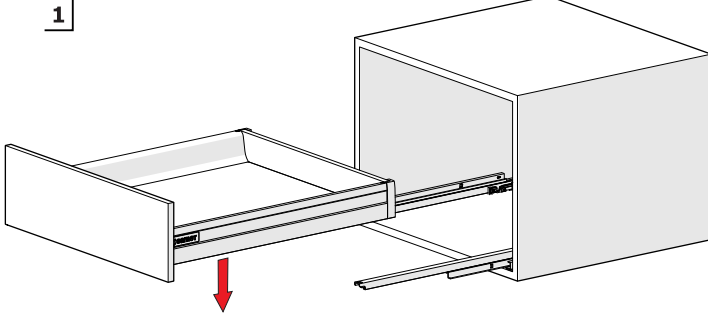

Çekmeceyi raya paralel gelecek şekilde koyup itiniz.
 Bitte setzen und schieben Sie die Schublade parallel auf die Führungsschienen.

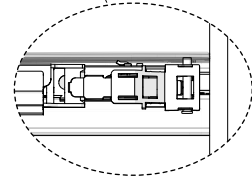
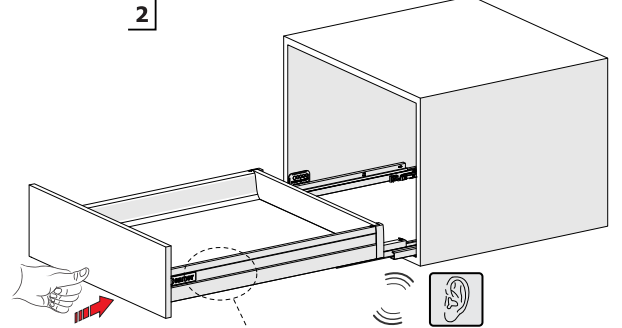

Altan görünüş
 Bodenansicht

Çekmecenin raydan çıkarılması
 Demontage der Schublade von der Führung
 Demontage des Schubkastens von der Führung
 Извлечение ящика
 将抽屉从滑轨上拆卸出来
 Le montage de la facade du tiroir
 Desmontaje del cajon de las guias
 Smontaggio del cassetto sulla guida
 Demontering av skuff fra renne
 슬라이드에서 서랍을 풀어내기
 Demontering av lådan från glidlisterna
 Demontowanie szuflady z prowadnicy
 Afmontering af skufferne fra glideskinne

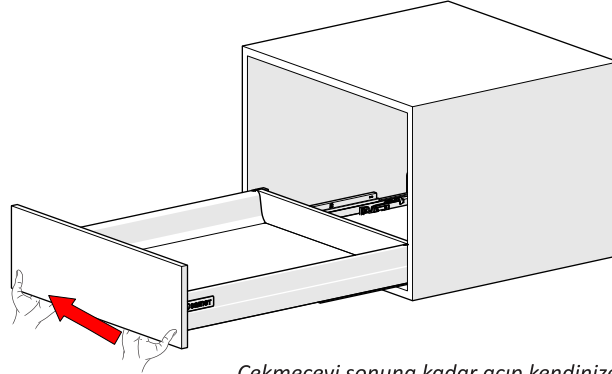

Çekmeceyi sonuna kadar açıp kendinize doğru hafifçe kaldırarak çekiniz.
 Bitte ziehen Sie die Schublade vollständig auf und heben diese

Kilit tırnağı kapanması durumunda / Im Falle einer nicht funktionierenden Verriegelung
 Im Falle eines nicht funktionierenden Verschlusses / В случае защелкивания замка
 系统失灵导致锁插槽关闭 / En cas où le système de fermeture ne fonctionne pas
 En el caso de cerrarse el mecanismo de enganche frontal / Per rimuovere pannello frontale
 Fjerning av frontpanel / 시스템장애때문에 잠근 경우 / Borttagning av frontpanel /
 Demontowanie panelu przedniego / Afmontering af fronten

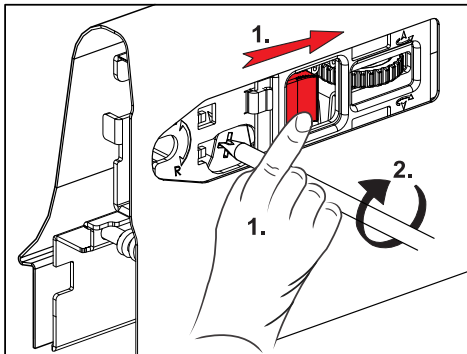

Ön paneli çıkarmak için / Frontplatte entfernen
 Demontage der Frontblende / Снятие передней панели
 拆卸前面板 / Le démontage de la facade du tiroir
 Para quitar el panel frontal / In caso di blocco della serratura
 Hvis låsen lukkes på grunn av systemfeil / 앞 패널 풀어내기
 Om låsspären stängs på grund av systemfel /
 Jeśli gniazda blokady zamykają się z powodu awarii systemu
 Hvis låsen ikke fungerer på grundlag af systemfejl

