

Schubladenlänge	Schrank-Innentiefe mit rückseitiger Befestigung		Schienenlänge (NL)	Schraubenpositionen für rahmenlose Schränke	
	Max	Min		A	B
229 (9")	310 (12-7/32")	270 (10-5/8")	261 (10-9/32")	133 (5-7/32")	229 (9")
305 (12")	368 (14-1/2")	328 (12-29/32")	319 (12-9/16")	165 (6-1/2")	261 (10-9/32")
381 (15")	444 (17-1/2")	404 (15-29/32")	395 (15-9/16")	165 (6-1/2")	357 (14-1/16")
457 (18")	520 (20-1/2")	480 (18-29/32")	471 (18-17/32")	261 (10-9/32")	453 (17-27/32")
533 (21")	597 (23-1/2")	557 (21-15/16")	548 (21-9/16")	261 (10-9/32")	517 (20-3/8")

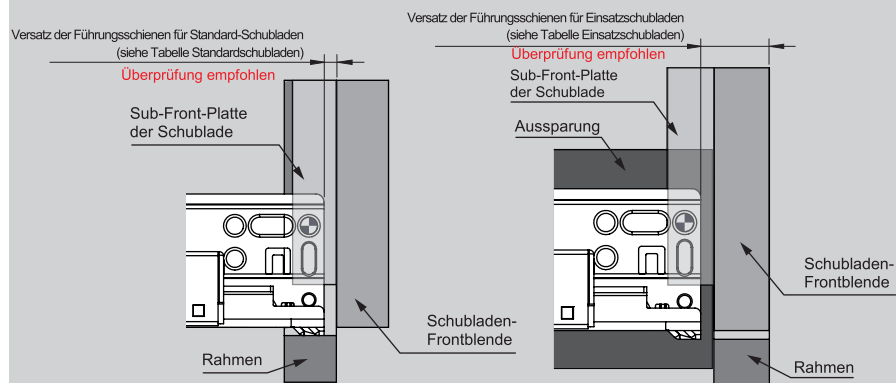

Standard-Schubladen		Versatz	
Stärke der Sub-Front-Platte	13 (1/2")	1.5 (1/16")	4.5 (3/16")
	16 (5/8")	4.5 (3/16")	7.5 (5/16")
	19 (3/4")		

Einsatzschublade		Versatz			
Stärke der Sub-Front-Platte	13 (1/2")	17.5 (11/16")	20.5 (13/16")	23.5 (15/16")	26.5 (1-1/32")
	16 (5/8")	20.5 (13/16")	23.5 (15/16")	26.5 (1-1/32")	29.5 (1-5/32")
	19 (3/4")	23.5 (15/16")	26.5 (1-1/32")	29.5 (1-5/32")	
	16 (5/8")	19 (3/4")	22 (7/8")		
Stärke der Schubladen-Frontblende					

### Umrechnungstabelle von Millimeter in Zoll

1	1.5	2	3	4	5	5.5	6	7	8	9	9.5	10	11	12	13	13.5	14	15	16	17	17.5	18	19	20	20.5	21	22	23	24	24.5	25.4
1/32	1/16	3/32	1/8	5/32	3/16	7/32	1/4	9/32	5/16	11/32	3/8	13/32	7/16	15/32	1/2	17/32	9/16	19/32	5/8	21/32	11/16	23/32	3/4	25/32	13/16	27/32	7/8	29/32	15/16	31/32	1

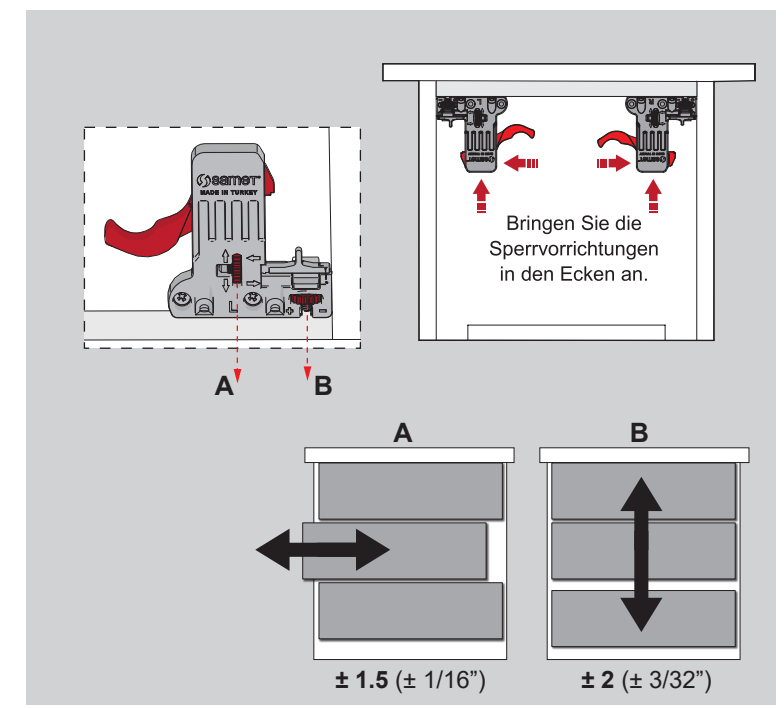
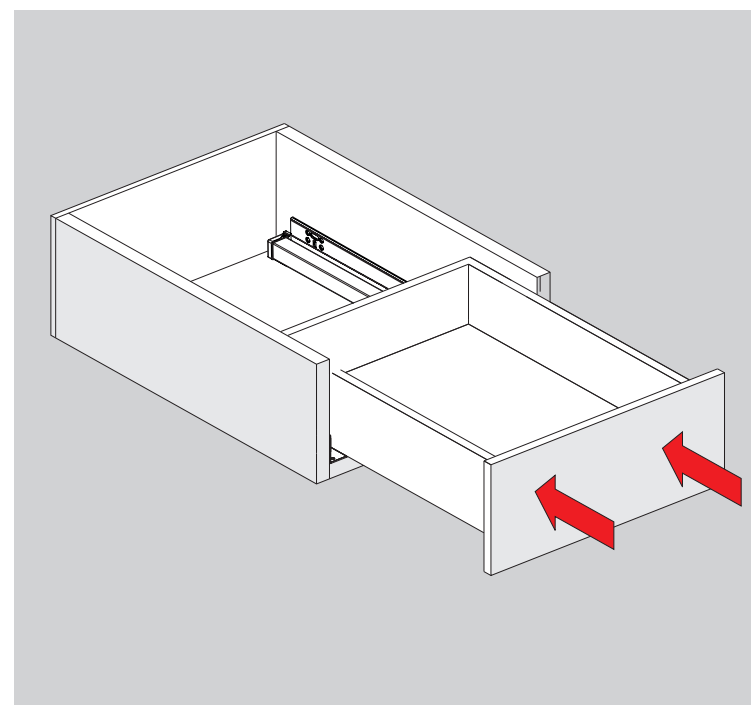
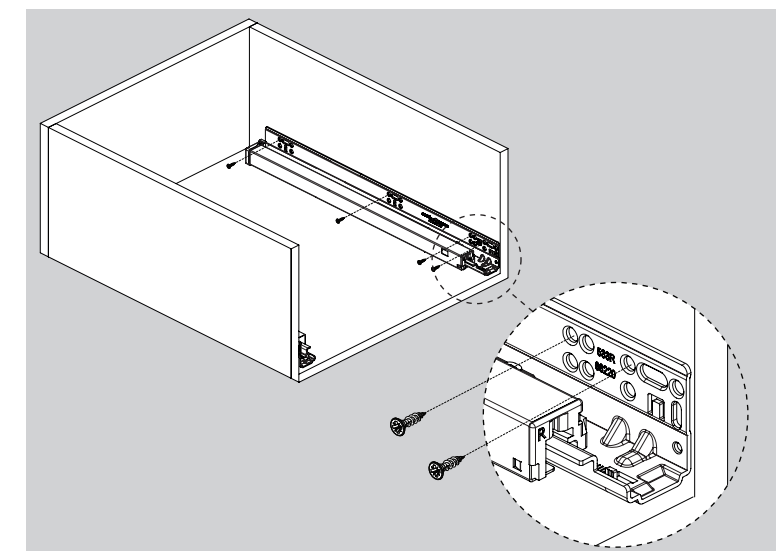
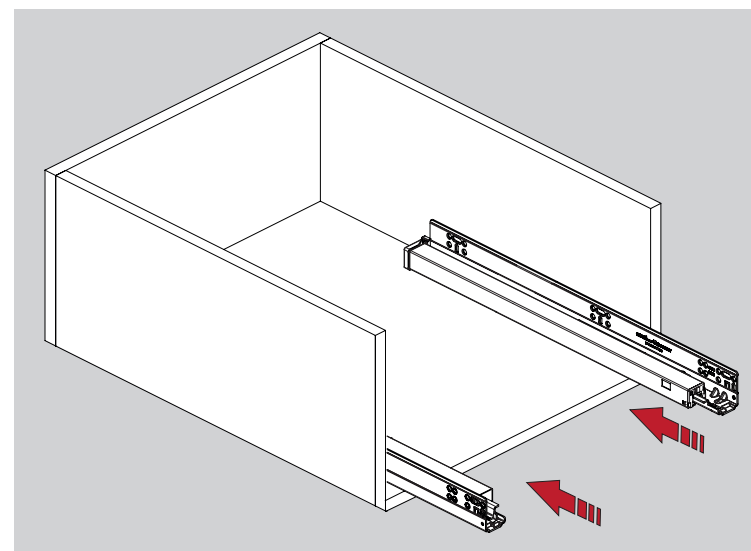
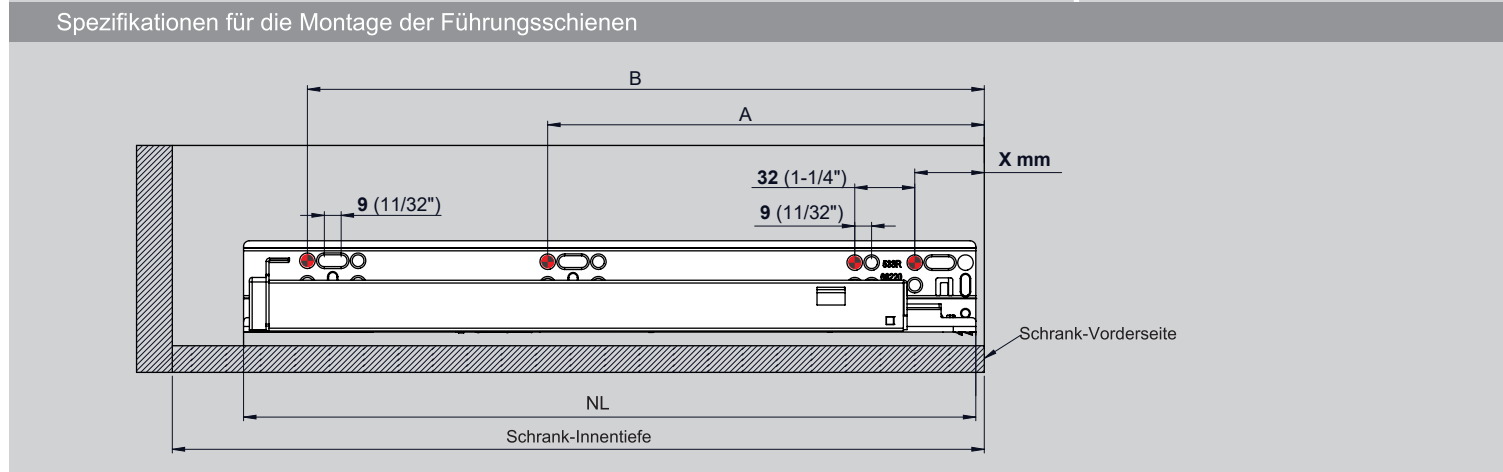
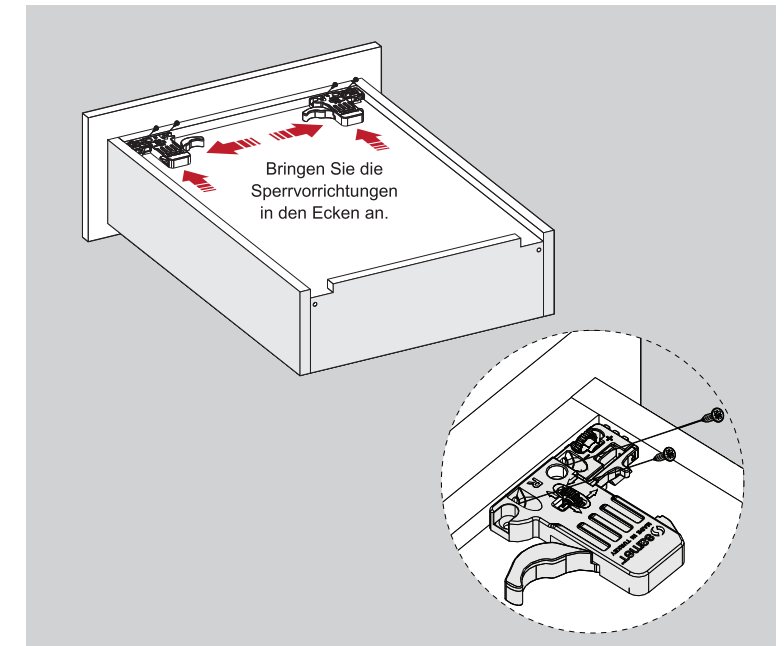
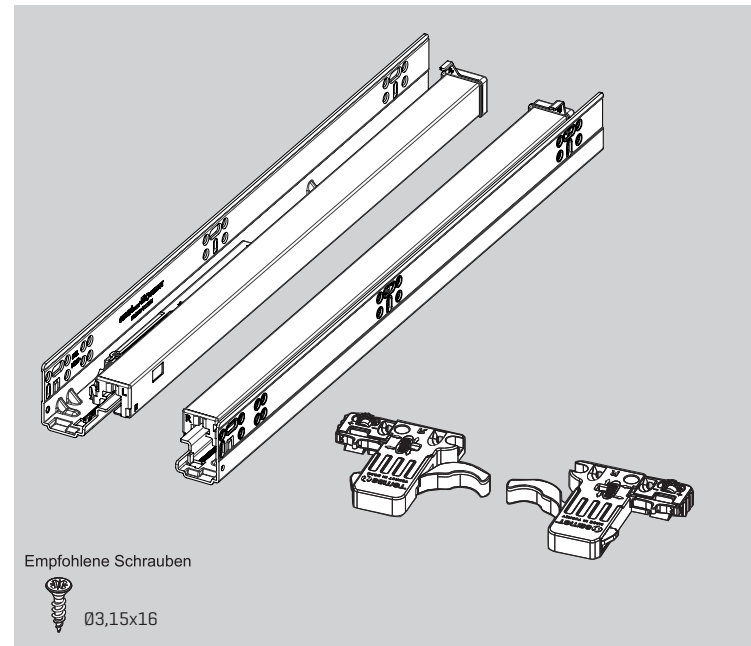
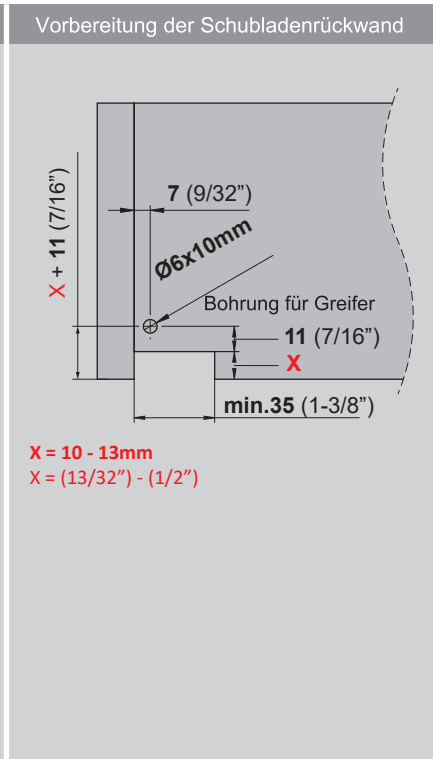
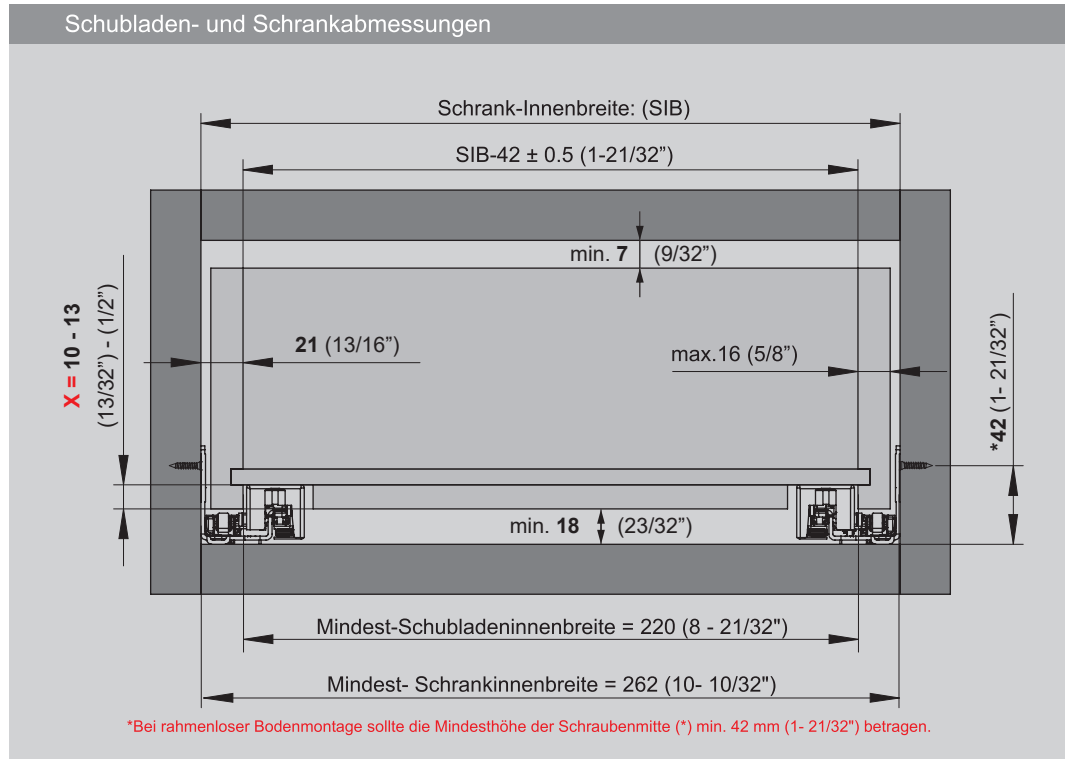

Schublad enlänge	Mindest- Schrankinnentiefe	Schienenlänge (NL)	Schraubenpositionen für rahmenlose Schränke	
			A	B
229 (9")	270 (10-5/8")	261 (10-9/32")	133 (5-7/32")	229 (9")
305 (12")	328 (12-29/32")	319 (12-9/16")	165 (6-1/2")	261 (10-9/32")
381 (15")	404 (15-29/32")	395 (15-9/16")	165 (6-1/2")	357 (14-1/16")
457 (18")	480 (18-29/32")	471 (18-17/32")	261 (10-9/32")	453 (17-27/32")
533 (21")	557 (21-15/16")	548 (21-9/16")	261 (10-9/32")	517 (20-3/8")

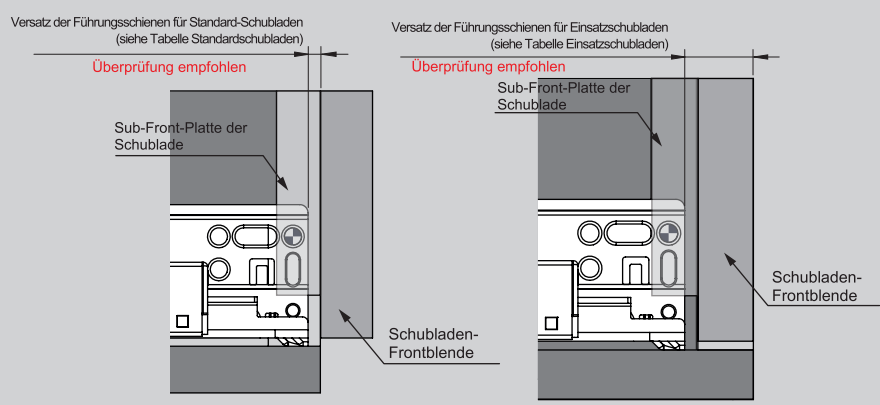

Standard-Schubladen		X (Bohrposition)	
Stärke der Sub-Front-Platte	13 (1/2")	34 (1-11/32")	
	16 (5/8")	37 (1-15/32")	
	19 (3/4")	40 (1-18/32")	

Einsetzschublade		X (Bohrposition)		
Stärke der Sub-Front-Platte	13 (1/2")	50 (1-31/32")	53 (2-3/32")	56 (2-7/32")
	16 (5/8")	53 (2-3/32")	56 (2-7/32")	59 (2-10/32")
	19 (3/4")	56 (2-7/32")	59 (2-10/32")	62 (2-14/32")
		16 (5/8")	19 (3/4")	22 (7/8")
Stärke der Schubladen-Frontblende				

### Umrechnungstabelle von Millimeter in Zoll

1	1.5	2	3	4	5	5.5	6	7	8	9	9.5	10	11	12	13	13.5	14	15	16	17	17.5	18	19	20	20.5	21	22	23	24	24.5	25.4
1/32	1/16	3/32	1/8	5/32	3/16	7/32	1/4	9/32	5/16	11/32	3/8	13/32	7/16	15/32	1/2	17/32	9/16	19/32	5/8	21/32	11/16	23/32	3/4	25/32	13/16	27/32	7/8	29/32	15/16	31/32	1