

### Kabin Ölçüleri / Schrankabmessungen

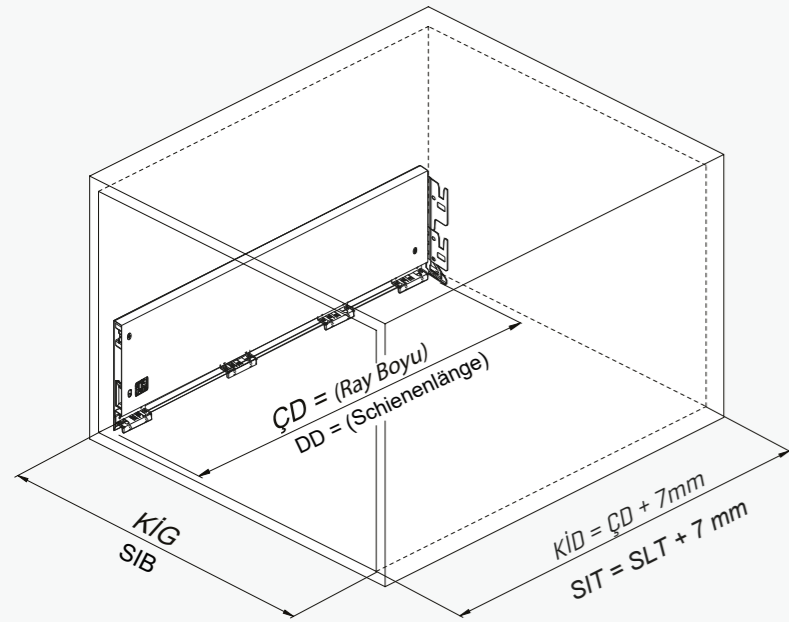

### Rayların Vida Konum Ölçüleri / Schraubenposition der Schienenführungen

Rayı, koyu renk ile işaretlenmiş deliklerden vidalayınız.  
Schrauben Sie die Schiene an den markierten Löchern fest.

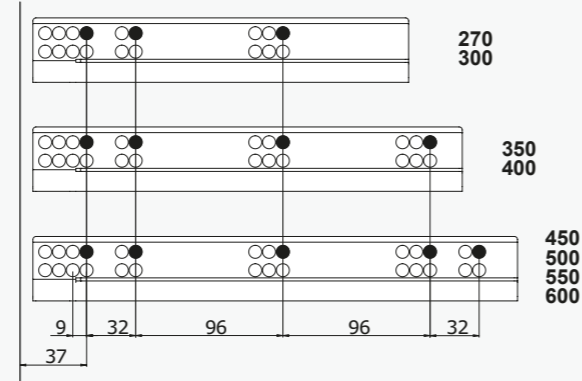

### Rayların Vida Konum Ölçüleri / Schraubenposition der Schienenführungen

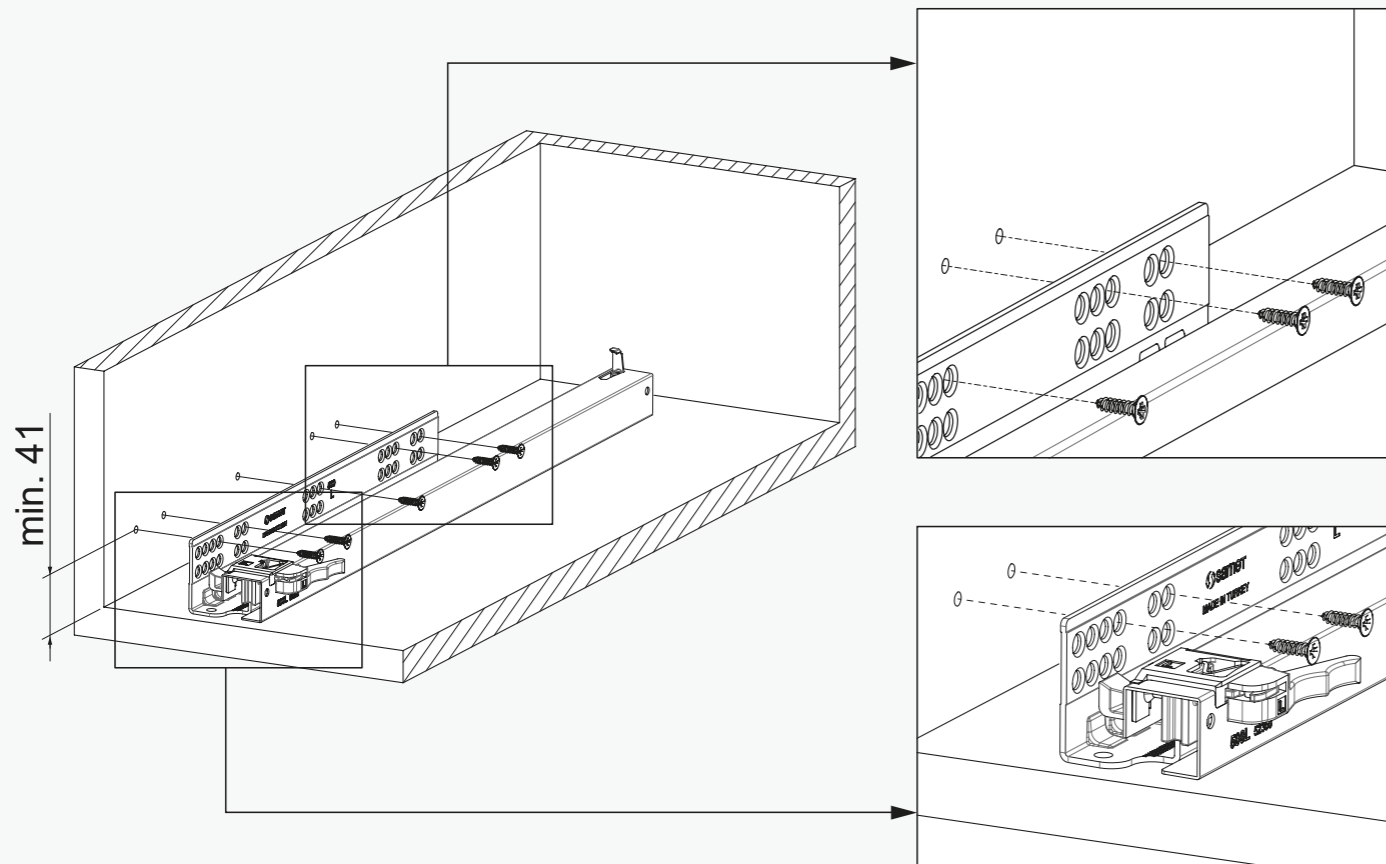

### Parçalar / Teile

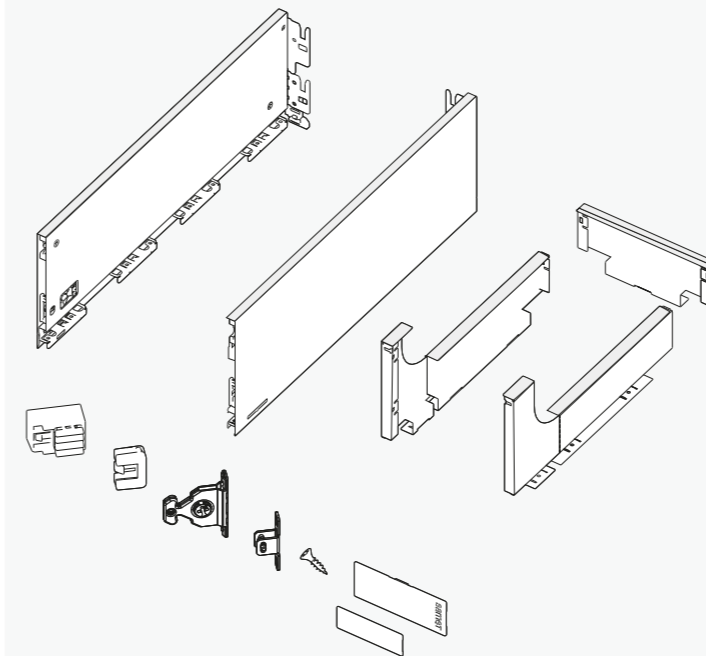

### Bordürsüz Ön Panel & Bağlantı Parçası Ohne Relingstab -Frontblende & Verbindungsstücke

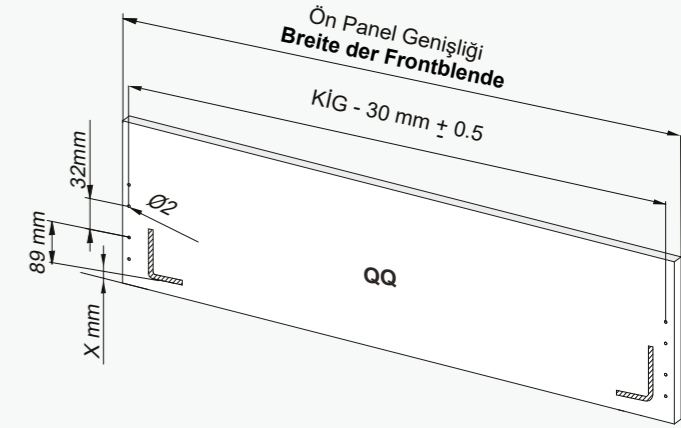

### Teknik Ölçüler / Technische Abmessungen

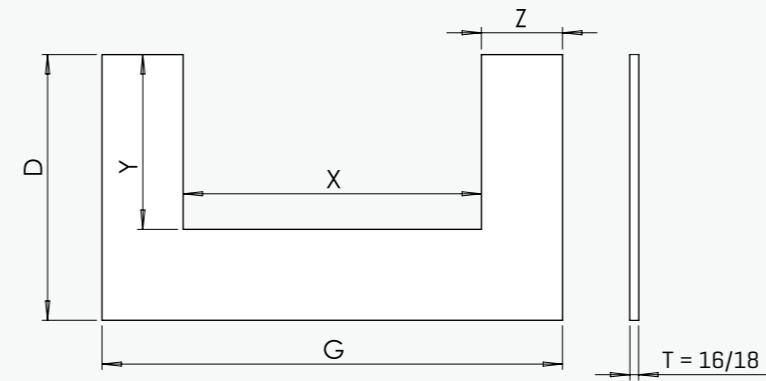

T = Sipariş sırasında belirlenen taban tahtası kalınlığı.  
Stärke der Grundplatte, die bei der Bestellung festgelegt wird.

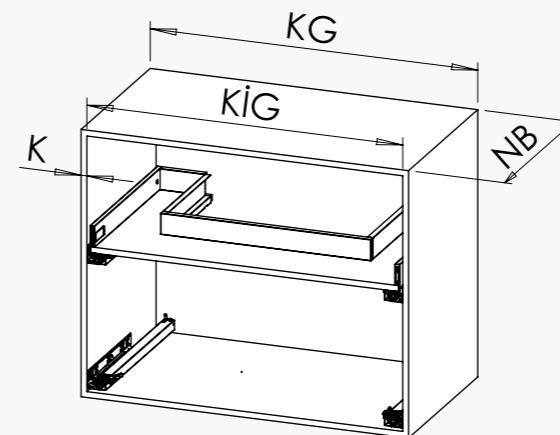

K = 16mm	KG:450	KG:600	KG:900	KG:1200
NB:350	X:160 Y:243 Z:117,5 D:338 G:396	X:160 Y:243 Z:192,5 D:338 G:546	X:160 Y:243 Z:342,5 D:338 G:846	X
NB:450	X:160 Y:243 Z:117,5 D:438 G:396	X:160 Y:243 Z:192,5 D:438 G:546	X:547 Y:271 Z:149 D:438 G:846	X
NB:500	X:160 Y:243 Z:117,5 D:488 G:396	X:160 Y:243 Z:192,5 D:488 G:546	X:547 Y:321 Z:149 D:488 G:846	X:547 Y:321 Z:299 D:488 G:1146
K = 18mm	KG:450	KG:600	KG:900	KG:1200
NB:350	X:156 Y:243 Z:117,5 D:338 G:392	X:156 Y:243 Z:192,5 D:338 G:542	X:156 Y:243 Z:342,5 D:338 G:842	X
NB:450	X:156 Y:243 Z:117,5 D:438 G:392	X:156 Y:243 Z:192,5 D:438 G:542	X:543 Y:271 Z:149 D:438 G:842	X
NB:500	X:156 Y:243 Z:117,5 D:488 G:392	X:156 Y:243 Z:192,5 D:488 G:542	X:543 Y:321 Z:149 D:488 G:842	X:543 Y:321 Z:299 D:488 G:1142

Montaj / Montage

