

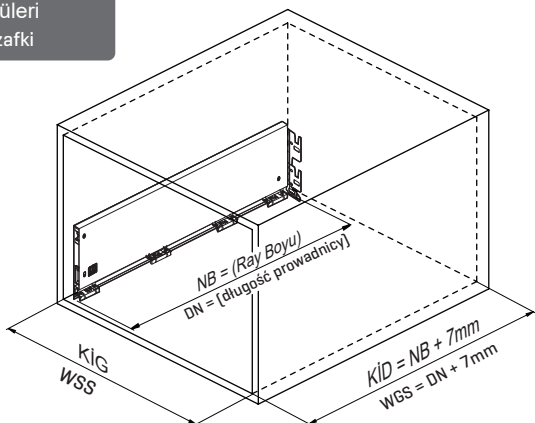

Kabin Ölçüleri Wymiary szafki



Rayların Vida Konum Ölçüleri

Rozmieszczenie wkrętów dla prowadnicy

Rayı işaretlenmiş deliklerden vidalayınız. Przekręćcić prowadnicę w zaznaczonych otworach.

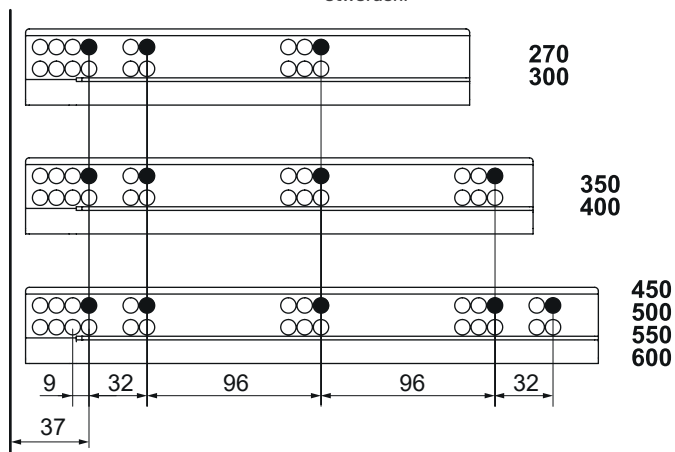

Bas - Aç Ray Ayarı

Regulacja prowadnicy Push - Open

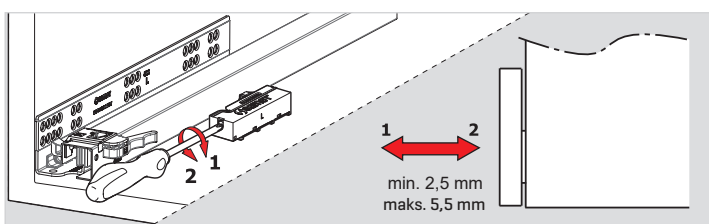

Ön Panel Panel przedni

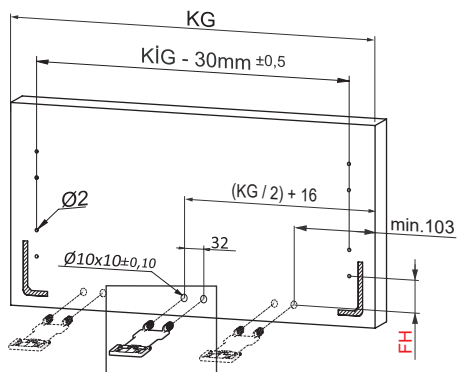

KIG ≥ 600mm

	16 mm Taban Tahtası Dno drewniane 16 mm	18 mm Taban Tahtası Dno drewniane 18 mm
FH	25	27

KIG : Kabin İç Genişliği
KID : Kabin İç Derinliği
NB : Nominal Boy
KG : Ön Panel Genişliği
B : Klapa Yan Binisi
X : Klapa Alt Binisi

WSS: Wewnętrzna szerokość szafki
WGS: Wewnętrzna głębokość szafki
DN: Długość nominalna
SPP: Szerokość panelu przedniego
B: Zakładka boczna panelu przedniego
X: Zakładka dolna panelu przedniego

Tavsiye Edilen Vida ve Şablonlar Zalecane wkręty i szablony

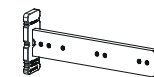

Smart EI Tipi Ray
Montaj Şablonu
Przyrząd Smart Drilling
Jig



Smart Cetvelli Ray
Montaj Şablonu
Przyrząd Smart Drilling Jig
z podziałką

Gövdede Yer İhtiyacı

Wymiary montażowe prowadnicy

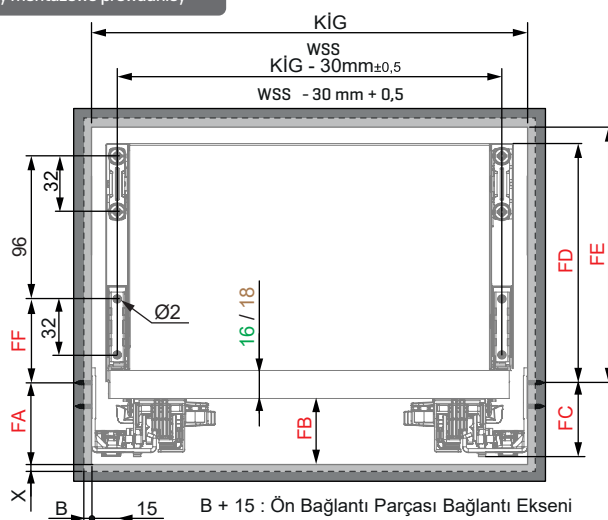

B + 15 : Ön Bağlantı Parçası Bağlantı Eksenini
B + 15: Wzorec nawiercania otworów na panelu przednim

16 mm Taban Tahtası Uygulaması Montaj przy dnie drewnianym 16mm

	SC		PO - YBA	
	H.192	H.256	H.192	H.256
FA	41		43	
FB	34		36	
FC	39		42	
FD	153	185	153	185
FE	157	189	157	189
FF	50		50	

/ Yavaşlatıcı Ray
/ Bas-Aç Ray
/ Yavaşlatıcı Bas-Aç Ray

18 mm Taban Tahtası Uygulaması Montaj przy dnie drewnianym 18mm

	SC		PO - YBA	
	H.192	H.256	H.192	H.256
FA	41		43	
FB	34		36	
FC	39		42	
FD	155	187	155	187
FE	159	191	159	191
FF	52		52	

Ahşap Çekmece Tabanı Dno szuflady drewnianej

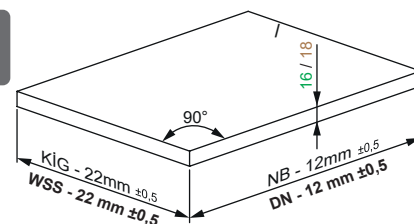

Ahşap Arkalık Drewniana płyta tylna

	H.192	H.256
FG	144	208

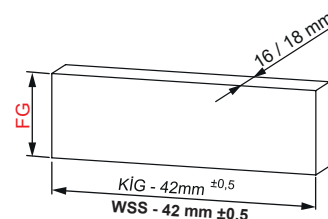



Montaj / Montaż

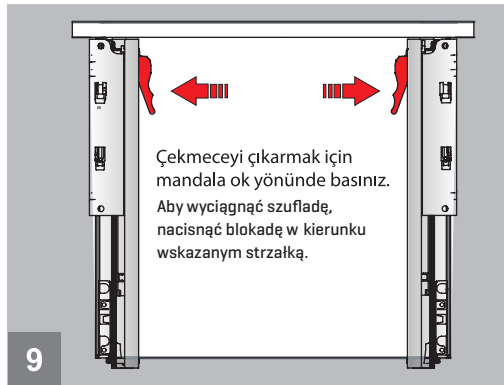
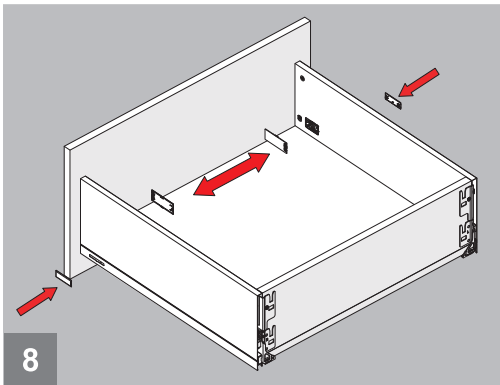
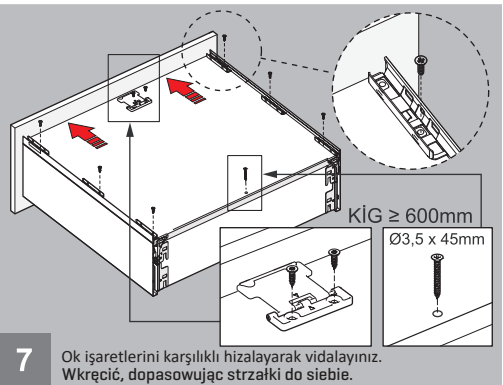
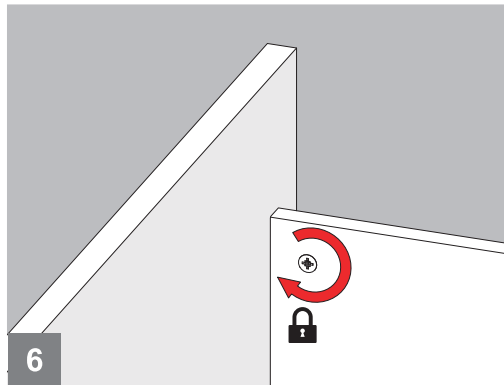
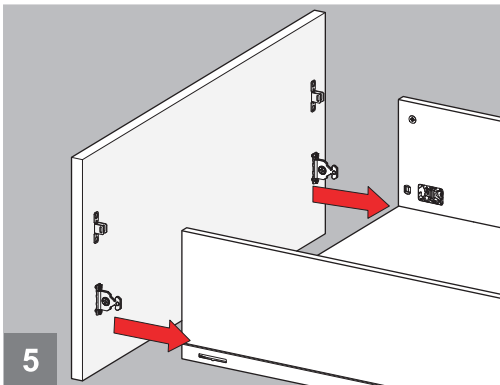
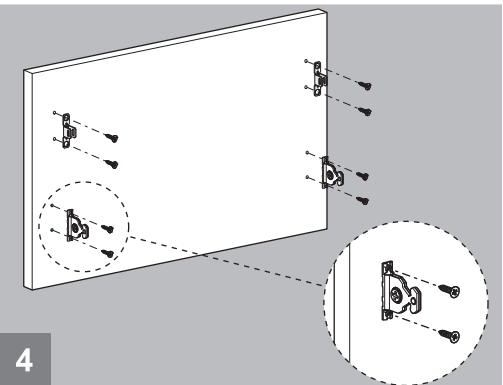
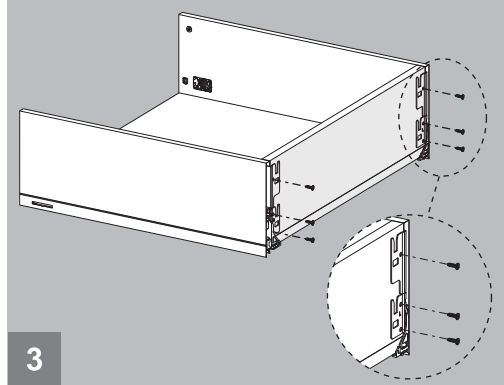
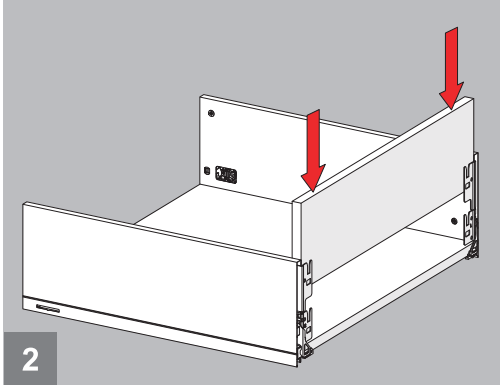
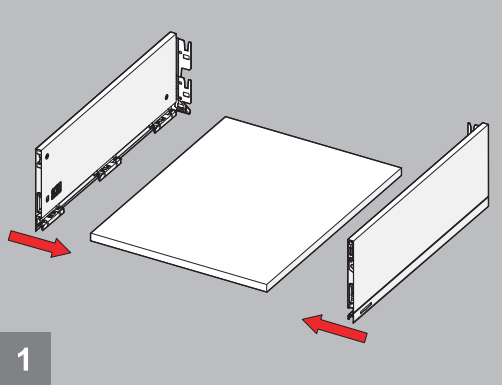

Ayar / Regulacja

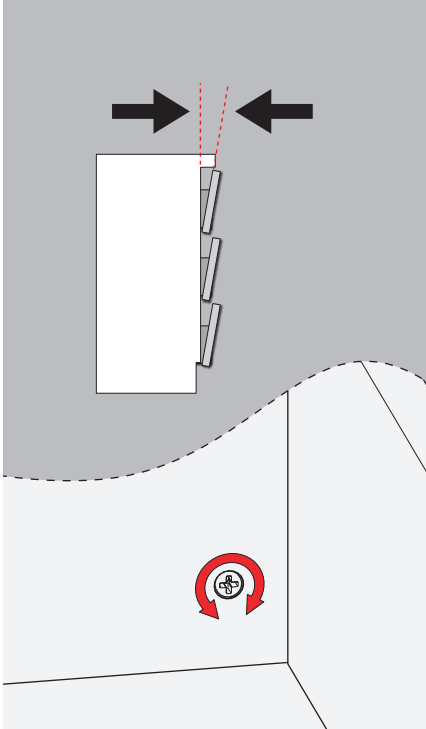
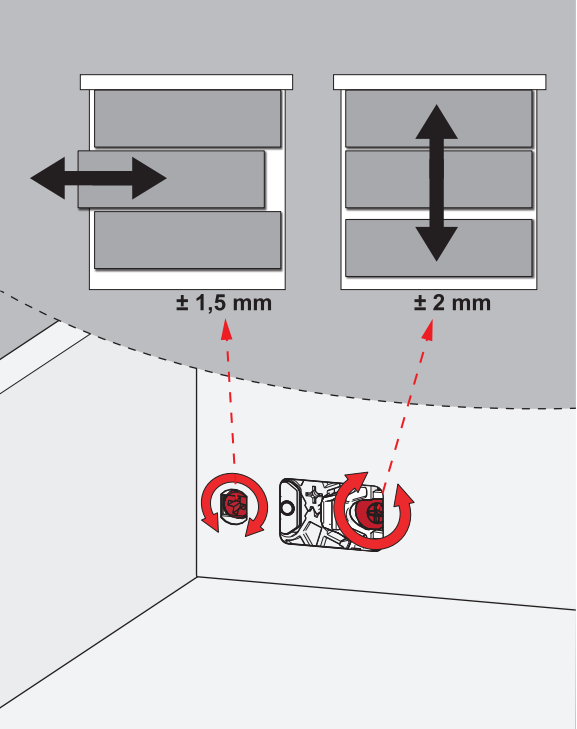

Önemli / Ważne

