

Kabin Ölçüleri / Wymiary szafki

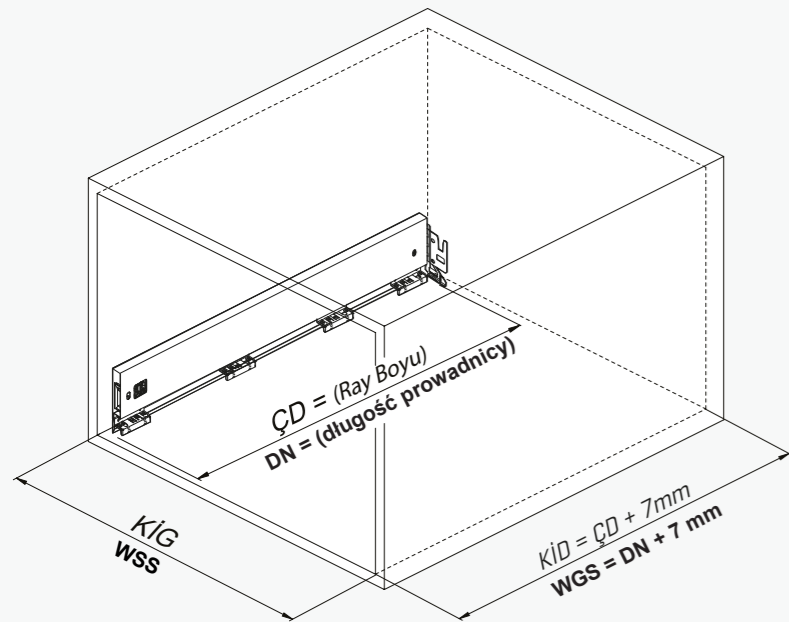

Rayların Vida Konum Ölçüleri / Rozmieszczenie wkrętów dla prowadnicy

Rayı, koyu renk ile işaretlenmiş deliklerden vidalayınız.  
 Przykręcić prowadnicę w oznaczonych otworach.

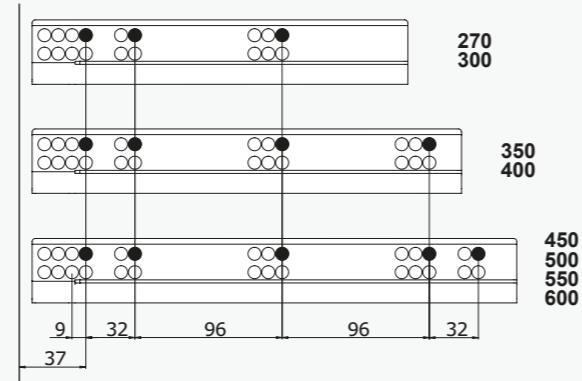

Parçalar / Części

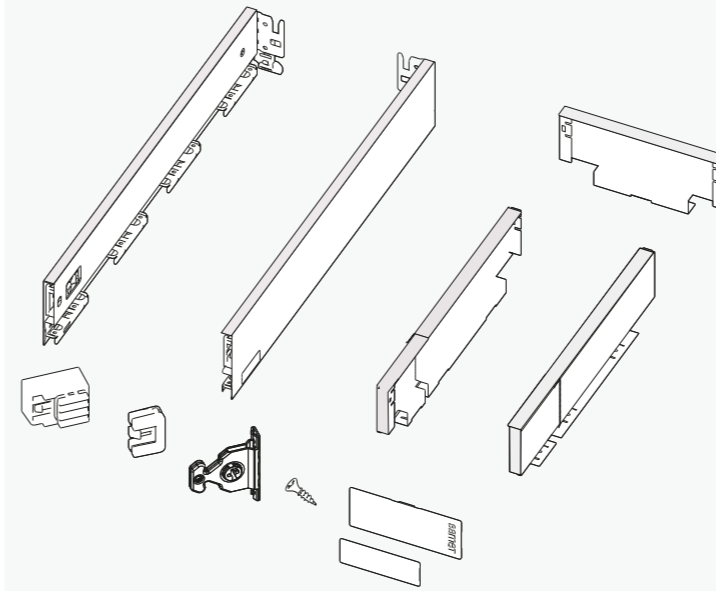

Bordürsüz Ön Panel & Bağlantı Parçası  
 Bez relingów panelu przedniego i elementów połączeniowych

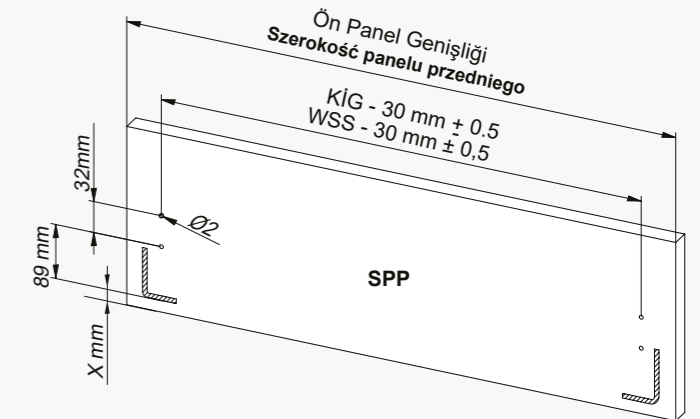

Rayların Vida Konum Ölçüleri / Rozmieszczenie wkrętów dla prowadnicy

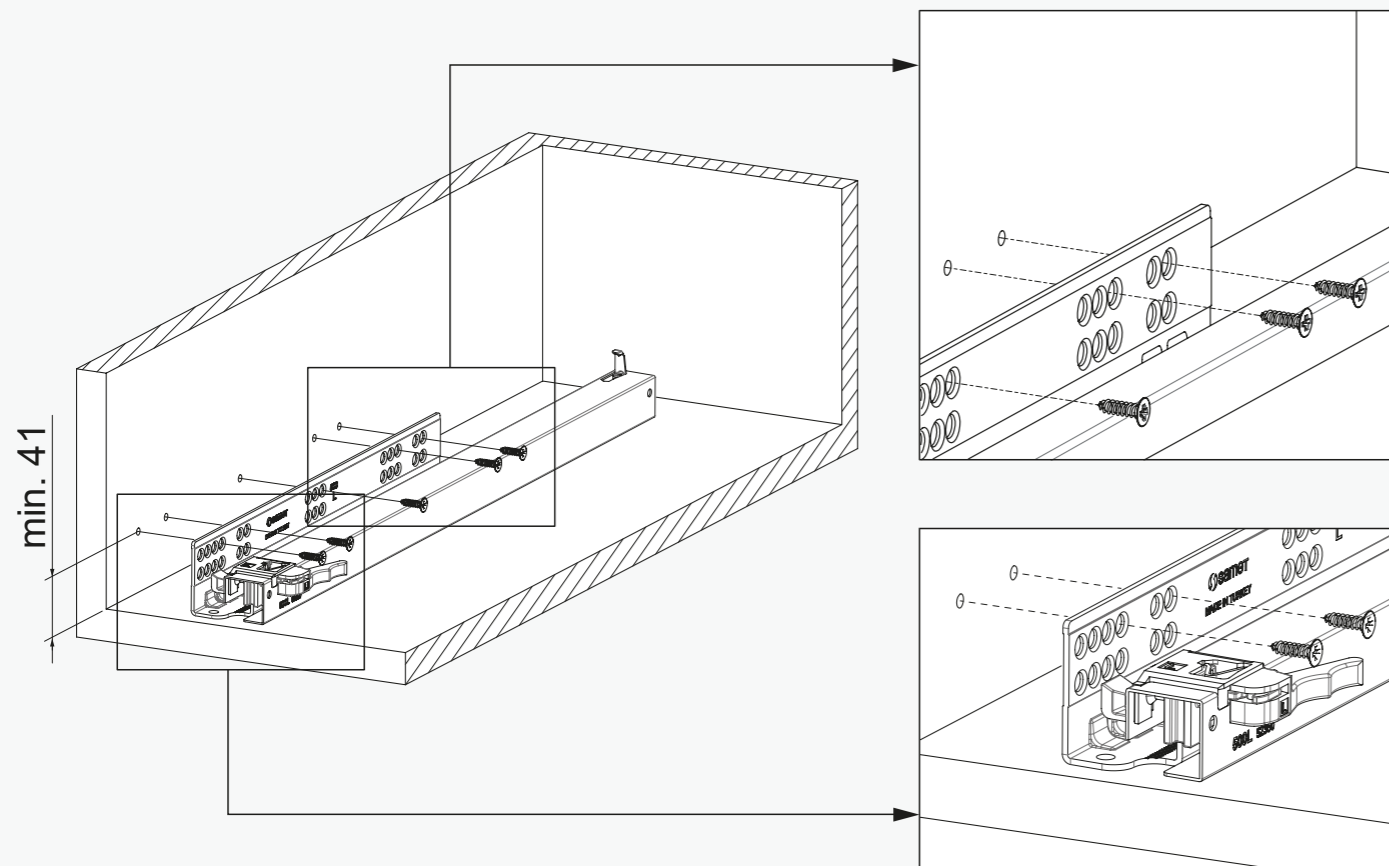

Teknik Ölçüler / Wymiary techniczne

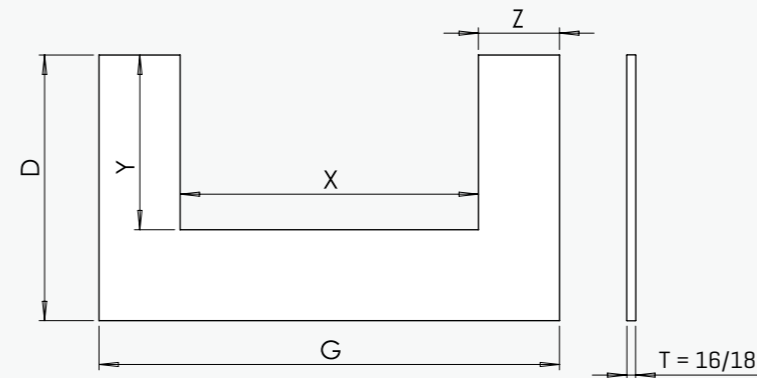

T = Sipariş sırasında belirlenen taban tahtası kalınlığı.  
 Grubość panelu podstawy określona podczas zamawiania.

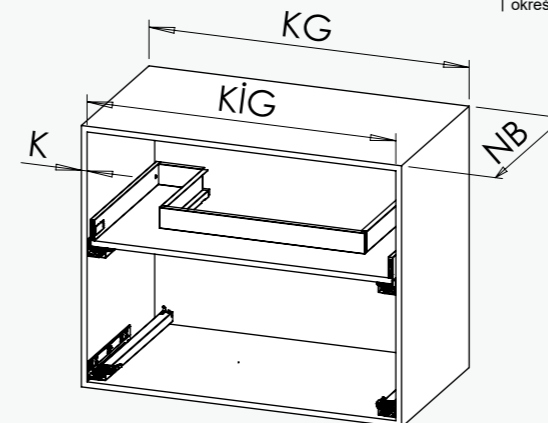

	K=16 mm	KG:450	KG:600	KG:900	KG:1200
NB:350	X:161	X:161	X:161		X
	Y:243	Y:243	Y:243		
	Z:117,5	Z:192,5	Z:342,5		
	D:338	D:338	D:338		
NB:450	X:161	X:161	X:548		X
	Y:243	Y:243	Y:271		
	Z:117,5	Z:192,5	Z:149		
	D:438	D:438	D:438		
NB:500	X:161	X:161	X:548	X:548	
	Y:243	Y:243	Y:321	Y:321	
	Z:117,5	Z:192,5	Z:149	Z:299	
	D:488	D:488	D:488	D:488	
K=18 mm	X:157	X:157	X:157		X
	Y:243	Y:243	Y:243		
	Z:117,5	Z:192,5	Z:342,5		
	D:338	D:338	D:338		
NB:450	X:157	X:157	X:544		X
	Y:243	Y:243	Y:271		
	Z:117,5	Z:192,5	Z:149		
	D:438	D:438	D:438		
NB:500	X:157	X:157	X:544	X:544	
	Y:243	Y:243	Y:321	Y:321	
	Z:117,5	Z:192,5	Z:149	Z:299	
	D:488	D:488	D:488	D:488	
K=18 mm	X:157	X:157	X:157		X
	Y:243	Y:243	Y:243		
	Z:117,5	Z:192,5	Z:342,5		
	D:338	D:338	D:338		
NB:450	X:157	X:157	X:544		X
	Y:243	Y:243	Y:271		
	Z:117,5	Z:192,5	Z:149		
	D:438	D:438	D:438		
NB:500	X:157	X:157	X:544	X:544	
	Y:243	Y:243	Y:321	Y:321	
	Z:117,5	Z:192,5	Z:149	Z:299	
	D:488	D:488	D:488	D:488	
K=18 mm	X:157	X:157	X:157		X
	Y:243	Y:243	Y:243		
	Z:117,5	Z:192,5	Z:342,5		
	D:338	D:338	D:338		
NB:450	X:157	X:157	X:544		X
	Y:243	Y:243	Y:271		
	Z:117,5	Z:192,5	Z:149		
	D:438	D:438	D:438		
NB:500	X:157	X:157	X:544	X:544	
	Y:243	Y:243	Y:321	Y:321	
	Z:117,5	Z:192,5	Z:149	Z:299	
	D:488	D:488	D:488	D:488	

Montaj / Montaż

