

Multi Mech

Mekanik İkili Kalkar Kapak Sistemi
Mechanisches Doppel-Hebetürsystem

Kullanım Kılavuzu Montageanleitung

Montaj Videosu | Montagevideo

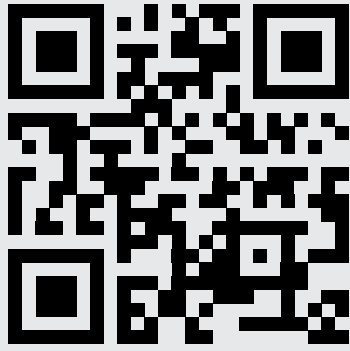

QR Kodu okutunuz
QR-Code scannen

UYGULAMALAR - ANWENDUNGEN

Tek Raf Uygulaması - Einzelregal-Anwendung

Simetrik Çift Raf Uygulaması - Symmetrische Doppelregal-Anwendung

Alüminyum Kapak Uygulaması - Aluminiumtür-Anwendung

İÇİNDEKİLER - INDEX

Parçalar - Teile

1

Montaj Ölçüleri - Montage-Maße

2 - 4

Şablonlar - Schablonen

5 - 6

Montaj / Montage

7 - 12

Kapak Ayarı - Türjustierung

13

Kapak Ağırlığına Göre Güç Ayarı - Belastbarkeit abhängig vom Türgewicht einstellbar

14

Kapanma Hızı (Damper) Ayarı - Soft Close-Justierung (Dämpfer)

15

Açılma Açısı Ayarı - Einstellung des Öffnungswinkels

16

Alüminyum Kapak Montajı - Aluminiumtür-Montage

17 - 20

Taşıma Kapasitesi - Çift Kapak Toplam Ağırlığı [Gr.]*
Belastungskapazität - Gesamtgewicht Zwei Türen [g] *

Kabin Yüksekliği [mm] Schrankhöhe [mm]	Hafif Yük Leichte Belastung [A1]		Orta Yük Mittlere Belastung [B1]		Ağır Yük Schwere Belastung [C1]	
	min.	max.	min.	max.	min.	max.
1001-1040	2300	5000	5000	9000	9000	14500
901-1000	2400	5500	5500	9500	9500	15000
861-900	2500	6000	6000	11000	11000	17000
801-860	2600	6500	6500	11500	11500	18000
761-800	2800	7200	7200	12500	12500	19000
721-760	2900	7500	7500	13000	13000	19500
701-720	3200	8000	8000	14000	14000	21000
651-700	3500	8500	8500	14500	14500	21500
601-650	4000	9000	9000	16000	16000	24000
561-600	4500	10000	10000	17000	17000	25000
501-560	5000	10500	10500	17500	17500	27000
480-500	5500	11500	11500	20000	20000	29000

Kabin Yüksekliği Schrankhöhe [mm]	Kol Boyu Armlänge [mm]
860 - 1040	345
700 - 859	237
600 - 699	195
480 - 599	145

*Kulp ağırlığı 100 gr. olarak ağırlığa dahil edilmiştir.

*Griffgewicht ist mit 100 g berücksichtigt.

Parçalar/ Teile

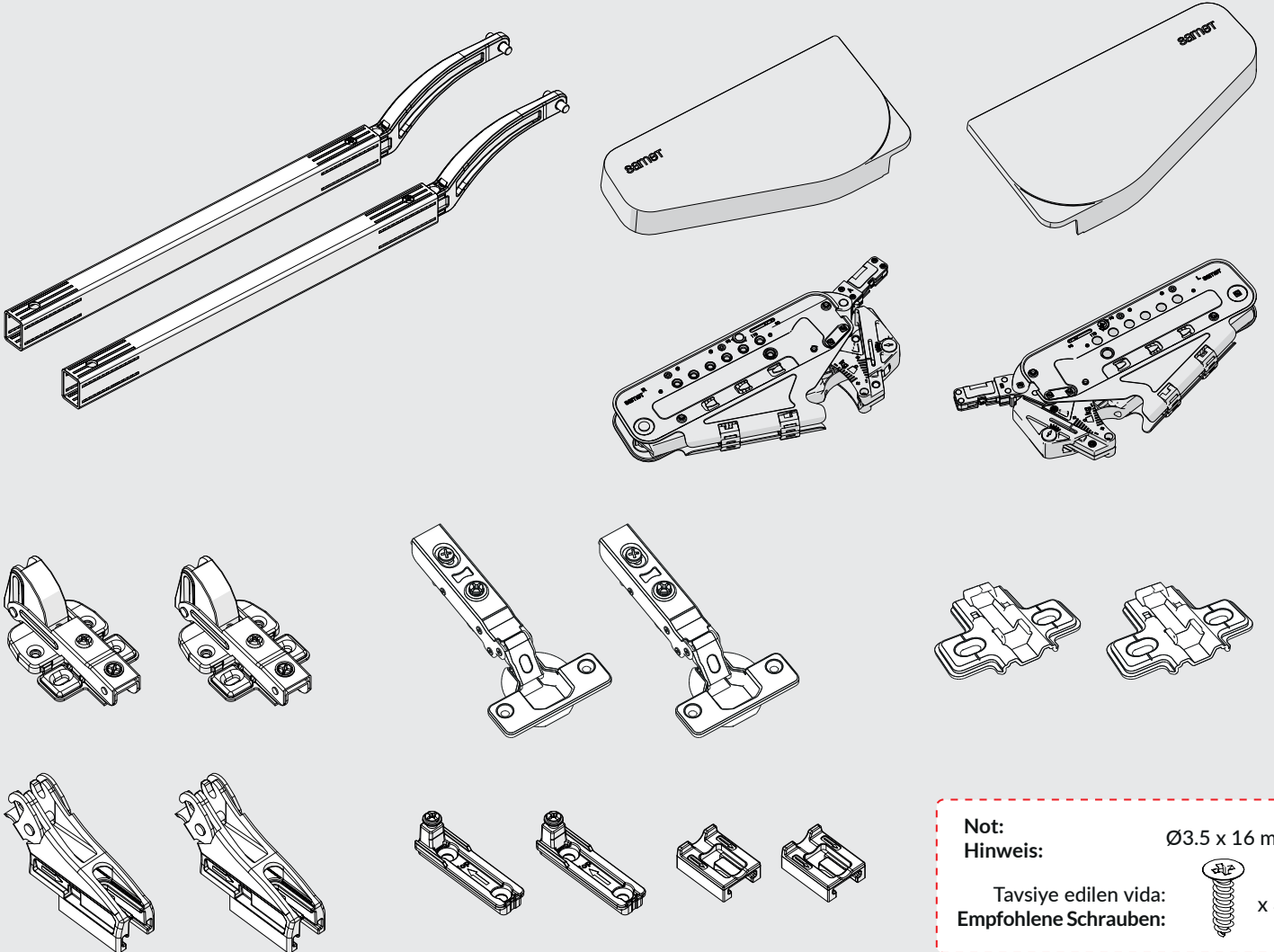

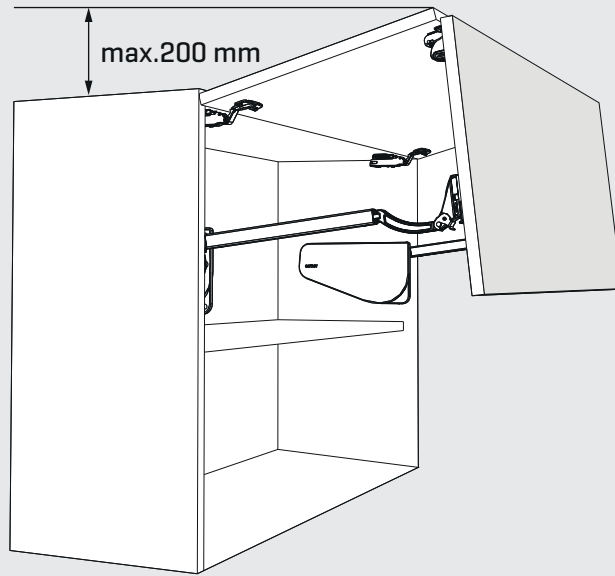

Teknik Ölçüler / Technische Abmessungen

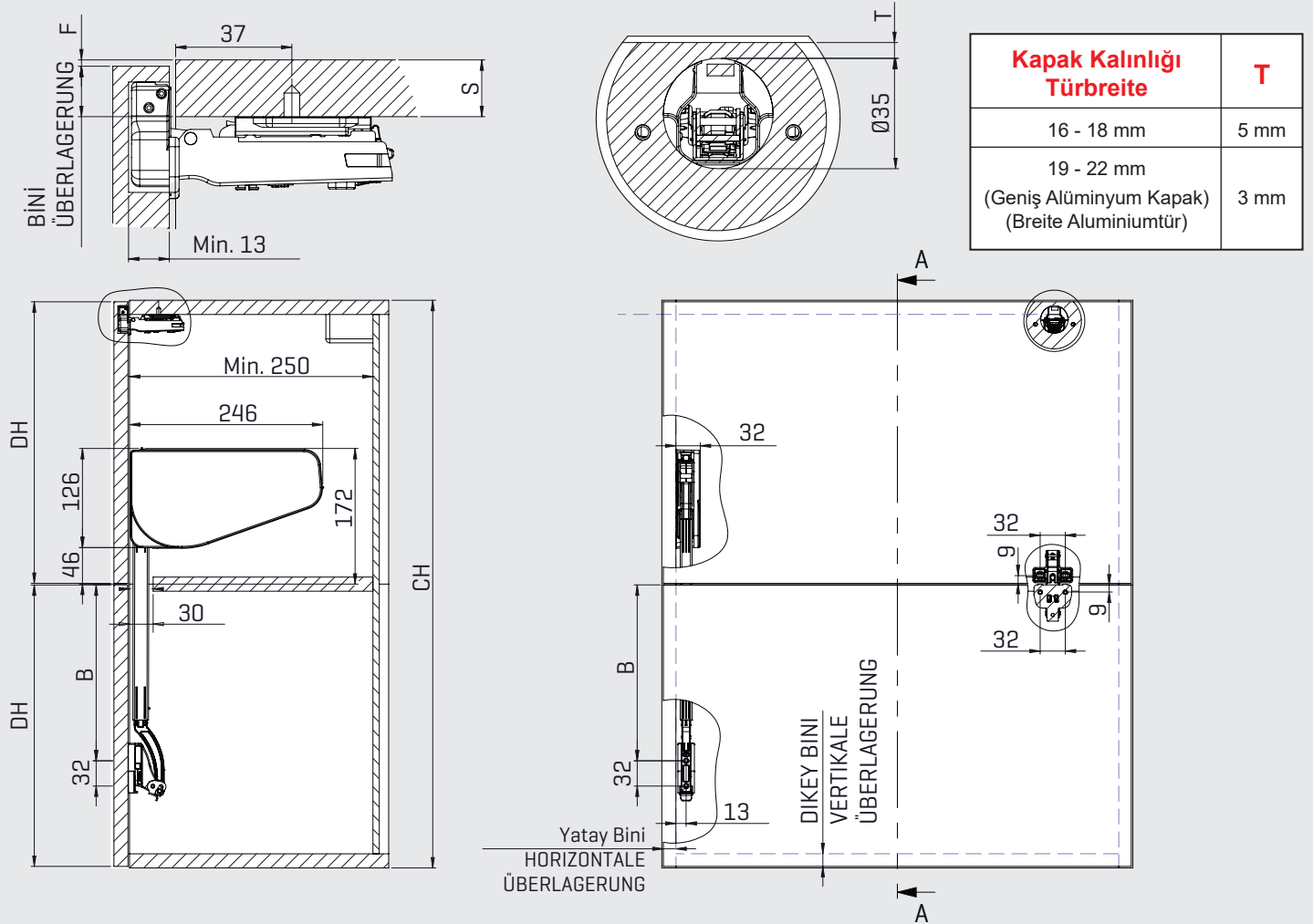

F: Fuga

T: Tas Mesafesi - Schalenabstand [3 - 6mm]

S: Tavan Kalınlığı - Schrank-Deckenstärke

S = T + F + 13

Not: Ölçüler mm cinsindedir.

Hinweis: Maßeinheit ist Millimeter.

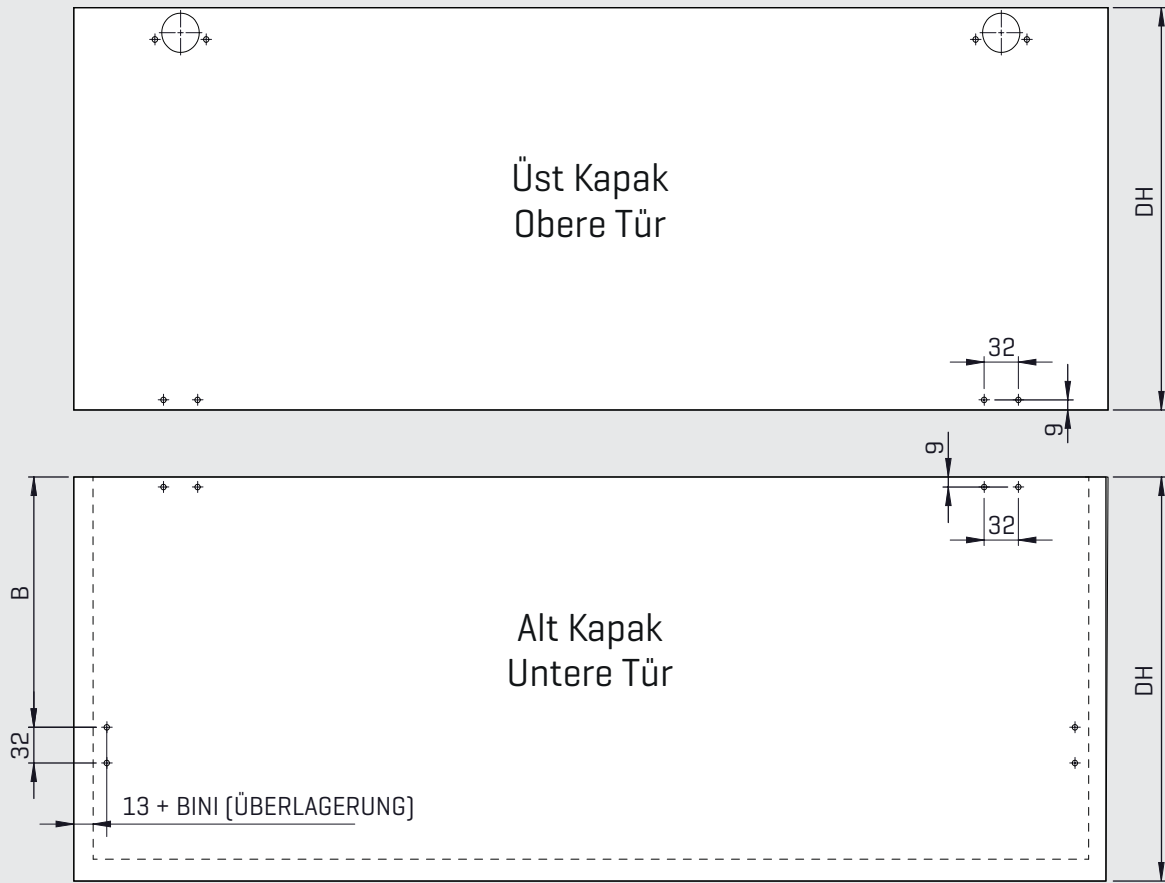

Tek Raf Uygulaması Einzelregal-Anwendung	
Kabin Yüksekliği Schrankhöhe [mm]	B mesafesi Abstand B [mm]
1040	383
1000	366
900	310
860	302
800	258
760	242
720	218
700	210
650	185
600	160
560	143
500	112
480	105

Simetrik İki Raf Uygulaması Symmetrische Doppelregal-Anwendung	
Kabin Yüksekliği Schrankhöhe [mm]	B mesafesi Abstand B [mm]
900	361
800	310
720	282

Not:

Tabloda belirtilmeyen kabin yükseklikleri için bir üst satırdaki ölçüler kullanılarak montaj yapılabilir.

Hinweis:

Für Schrankhöhen, die nicht in der Tabelle angegeben sind, kann der Einbau unter Verwendung der Angaben erfolgen, die in der oberen Zeile der Maßangaben aufgeführt sind, und die Ihrer Schrankhöhe am nächsten liegen.

DH: Kapak Yüksekliği - Türhöhe

Tek Raf Uygulaması - Einzelregal-Anwendung

Alüminyum Kapak Uygulaması - Aluminiumtür-Anwendung

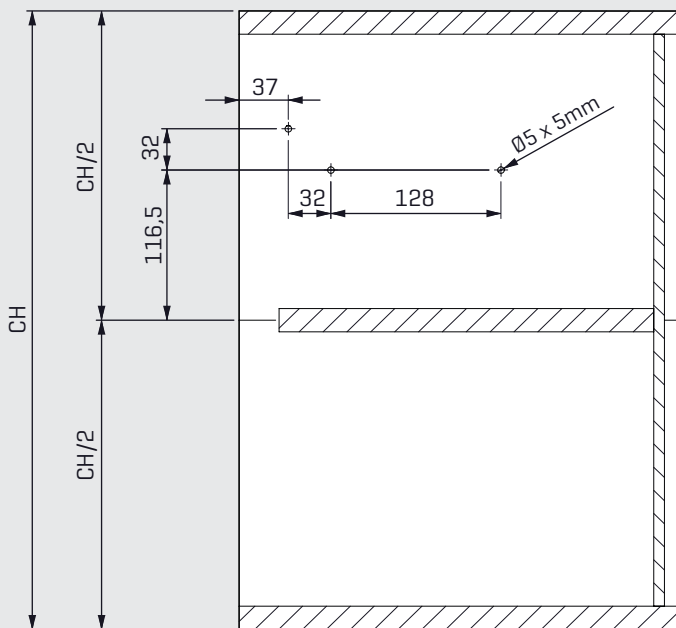

Gövde mekanizması sabitleme pimleri için delik merkezleri
Stiftmitte zum Anbringen des Mechanismus
 [Ø5 x 5 mm]

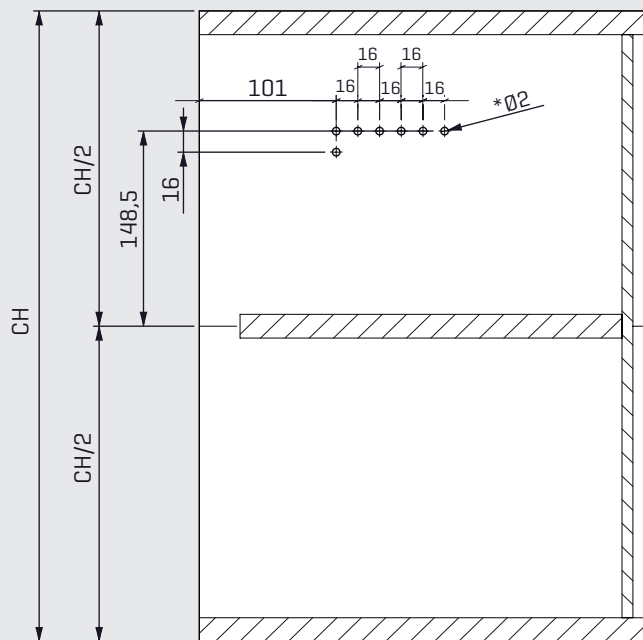

*Euro Vida kullanılacaksa delikler Ø5mm olarak delinmelidir.
 *Bei der Verwendung von Euro-Schrauben muss der Durchmesser der Löcher 05 mm betragen.

Simetrik Çift Raf Uygulaması - Symmetrische Doppelregal-Anwendung

Alüminyum Kapak Uygulaması - Aluminiumtür-Anwendung

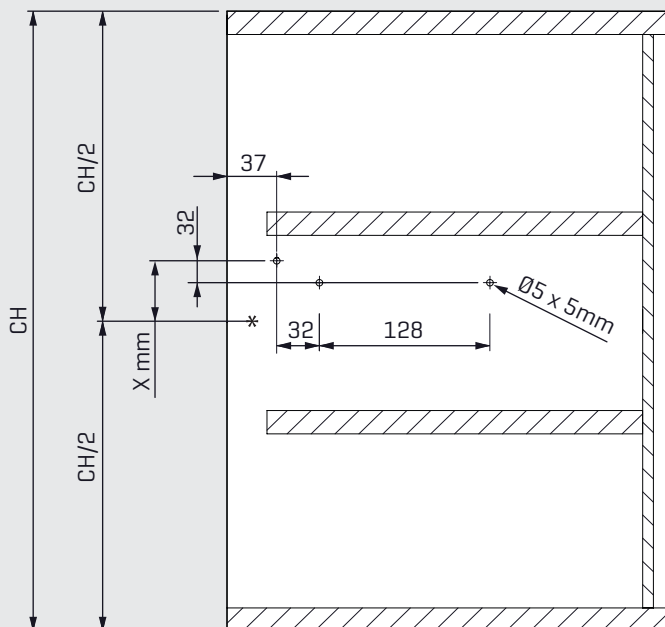

Gövde mekanizması sabitleme pimleri için delik merkezleri
Stiftmitte zum Anbringen des Mechanismus
 [Ø5 x 5 mm]

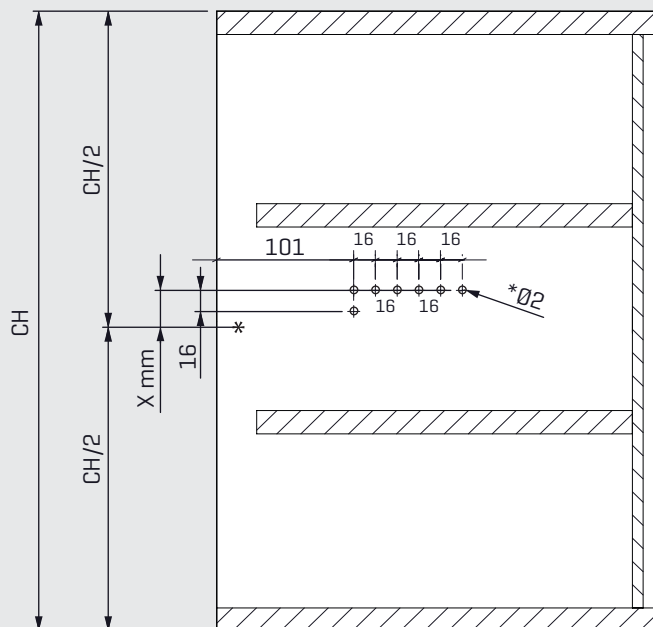

*Euro Vida kullanılacaksa delikler Ø5mm olarak delinmelidir.
 *Bei der Verwendung von Euro-Schrauben muss der Durchmesser der Löcher 05 mm betragen

CH (mm)	720	800	900
X (mm)	70	82	100

CH: Kabin Yüksekliği - Schrankhöhe

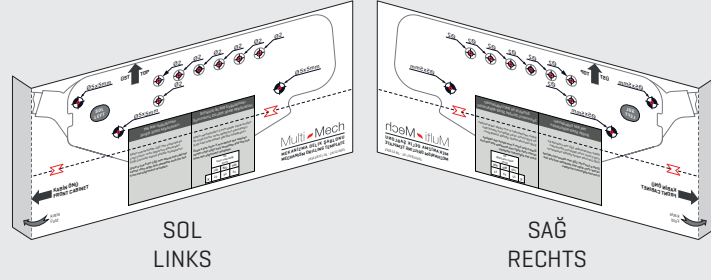

Tek Raf Uygulaması
Einzelregal-Anwendung

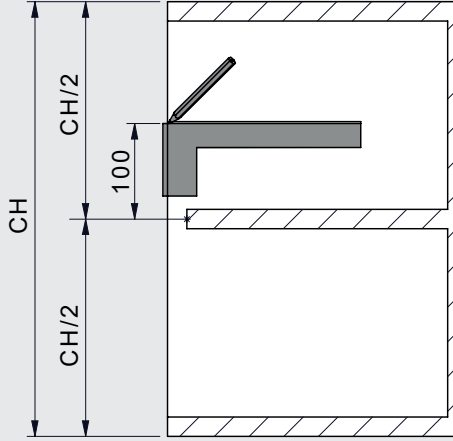

Simetrik İki Raf Uygulaması
Symmetrische Doppelregal-Anwendung

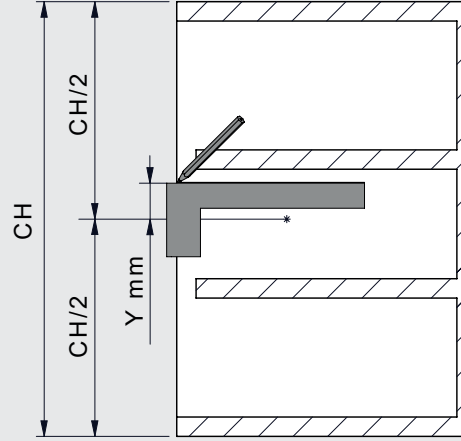

CH (mm)	720	800	900
Y (mm)	22	34	51

1

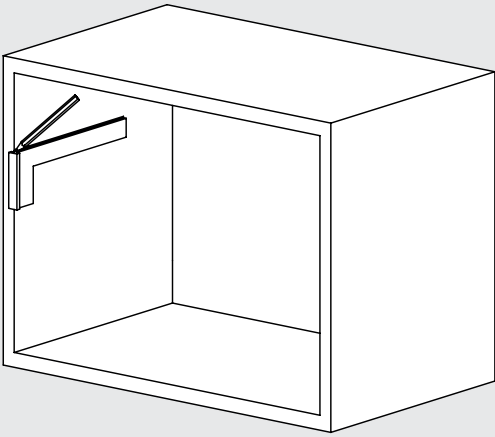

2

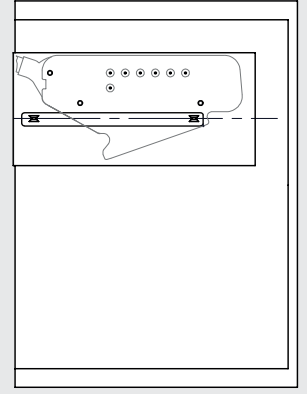
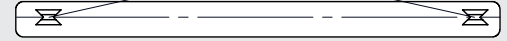
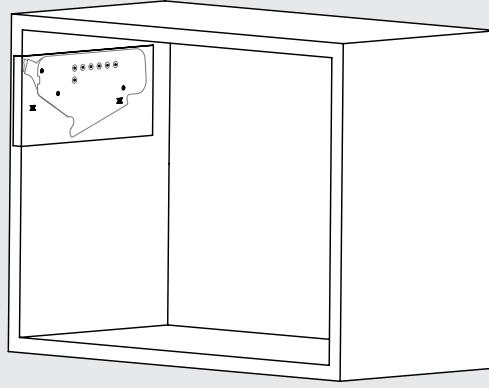

3

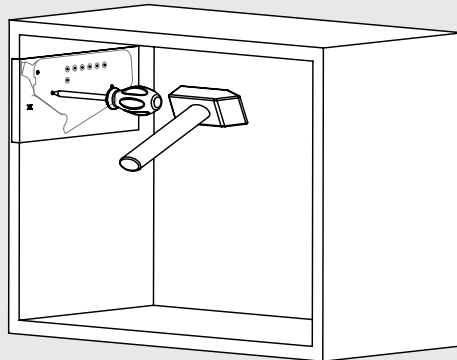

4

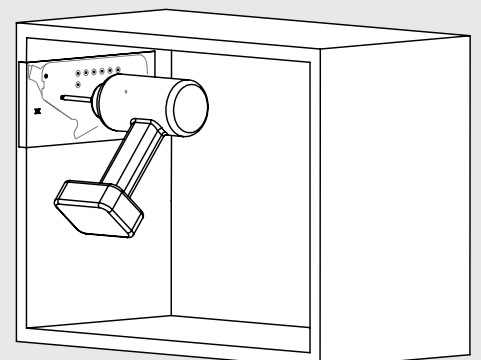

CH: Kabin Yüksekliği - Schrankhöhe

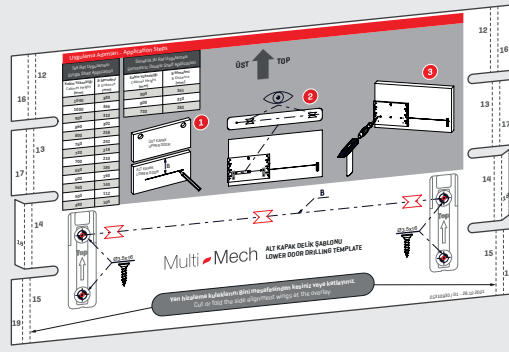

1

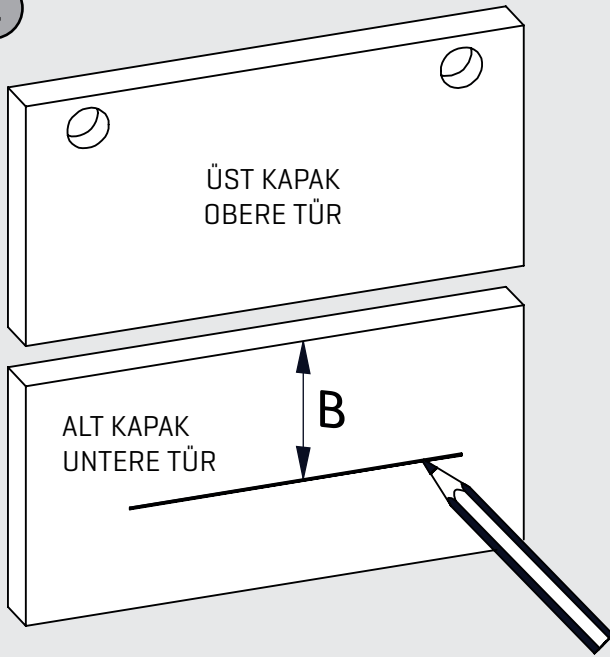

Tek Raf Uygulaması Einzelregal-Anwendung	
Kabin Yüksekliği Schrankhöhe [mm]	B Mesafesi Abstand B [mm]
1040	383
1000	366
900	310
860	302
800	258
760	242
720	218
700	210
650	185
600	160
560	143
500	112
480	105

Simetrik İki Raf Uygulaması Symmetrische Doppelregal-Anwendung	
Kabin Yüksekliği Schrankhöhe [mm]	B Mesafesi Abstand B [mm]
900	361
800	310
720	282

2

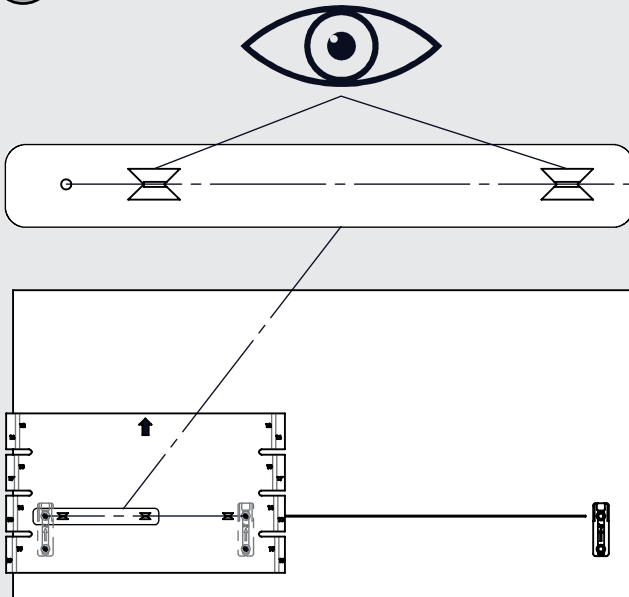

3

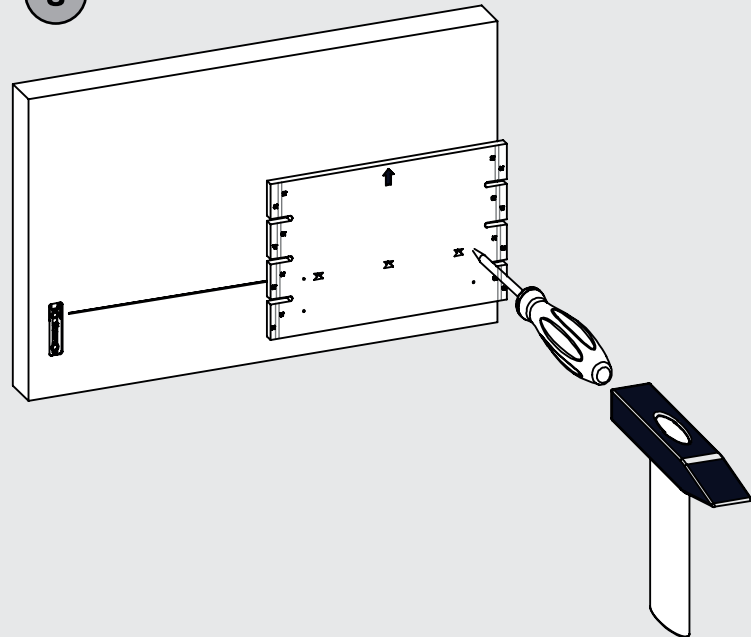

İŞLEM
SCHRITT 1

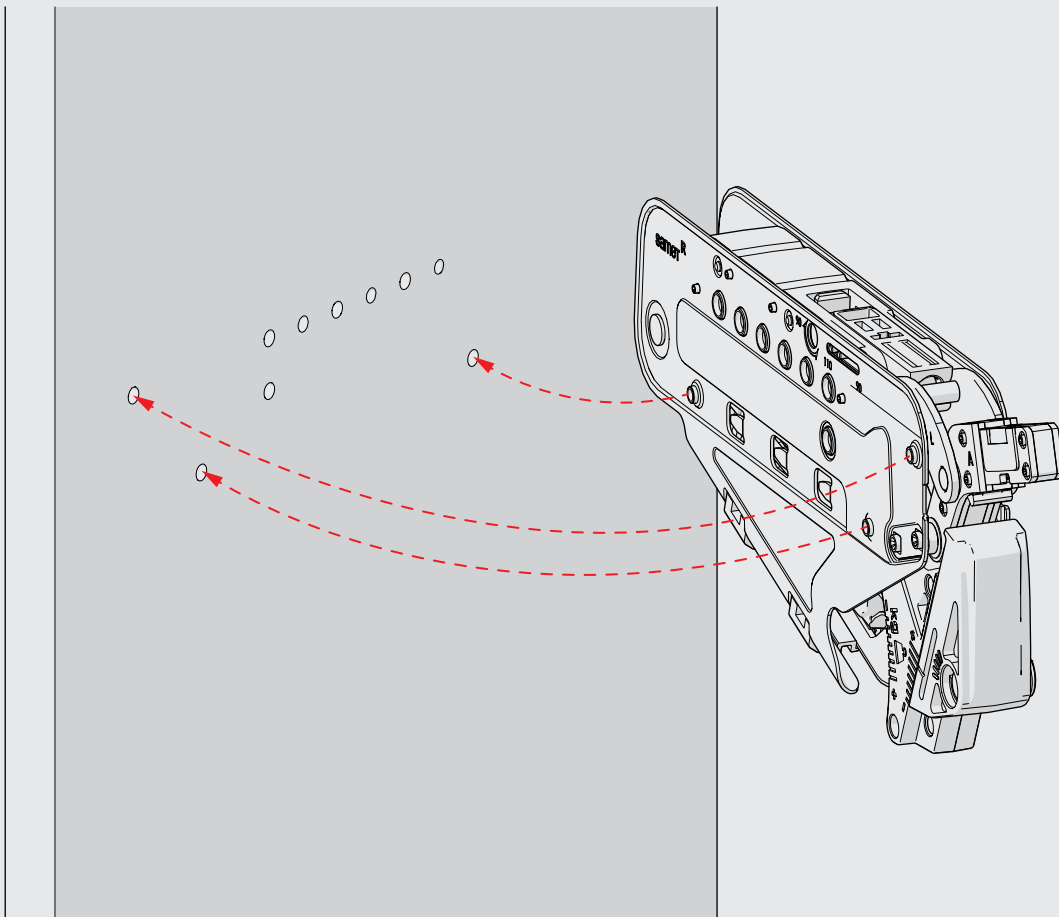

İŞLEM
SCHRITT 2

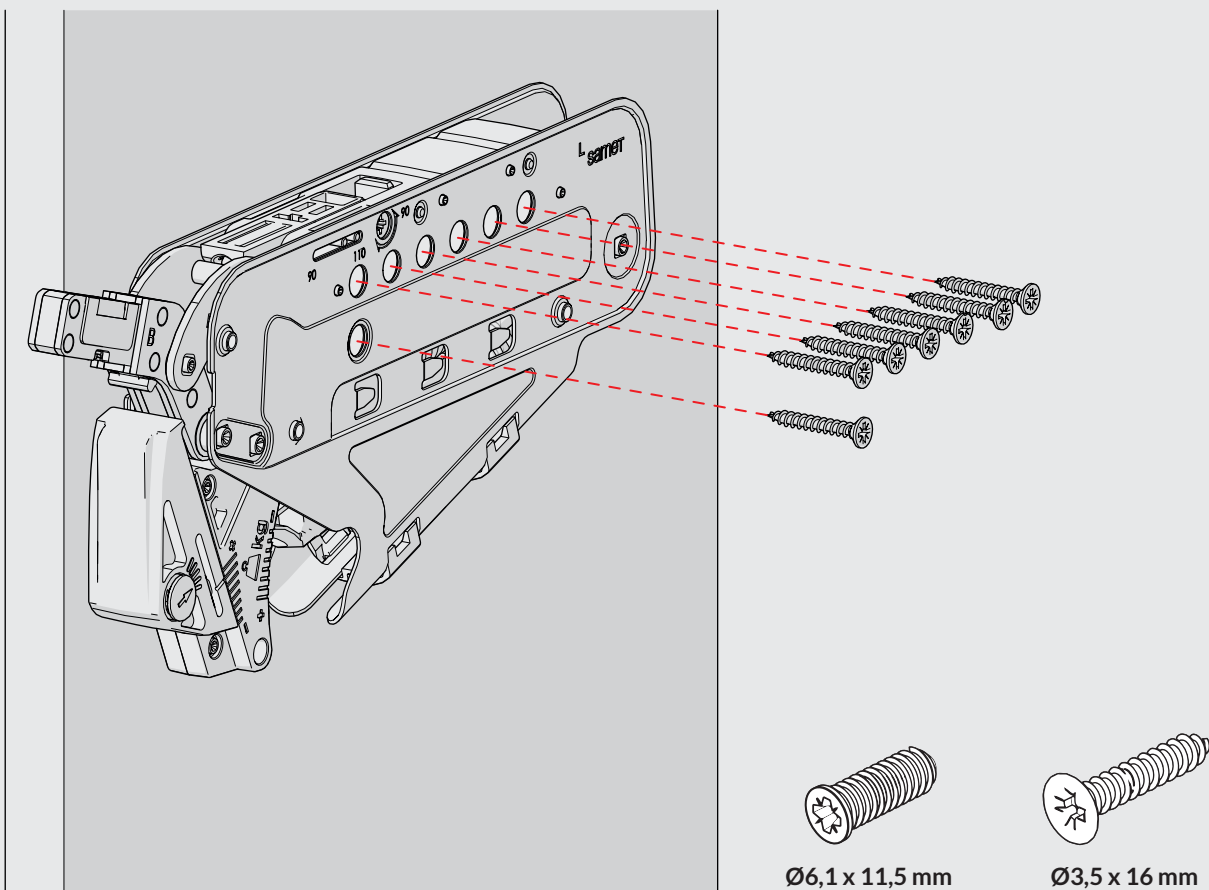

Montaj / Montage

İŞLEM SCHRITT 3

- 1 Vidayı gevşetin.
Lösen Sie die Schraube.
- 2 Teleskopik kol üzerinde bulunan delik numaralarına* göre gerekli kol uzunluğu ayarını yapınız.
Bitte stellen Sie sicher, dass Sie die richtige Länge für den Teleskoparm einstellen. Beachten Sie hierfür die Lochnummern*, die auf den Teleskoparmen angegeben sind.
- 3 Vidayı sıkıp sabitleyiniz.
Schraube eindrehen und festziehen.

*Uygun delik pozisyonları için tabloya bakınız.

* Bitte beachten Sie die Lochpositionstabelle für die richtige Lochposition.

Tek Raf Uygulaması Einzelregal-Anwendung		
Kabin Yüksekliği Schrankschöhe [mm]	Kol Boyu Armlänge [mm]	Delik No Lochnummer
1040	345	10
1000	345	8
900	345	1
860	345	0
800	237	8
760	237	6
720	237	3
700	237	2
650	195	4
600	195	1
560	145	5
500	145	1
480	145	0

Simetrik İki Raf Uygulaması Symmetrische Doppelregal-Anwendung		
Kabin Yüksekliği Schrankschöhe [mm]	Kol Boyu Armlänge [mm]	Delik No Lochnummer
900	345	1
800	237	6
720	237	1

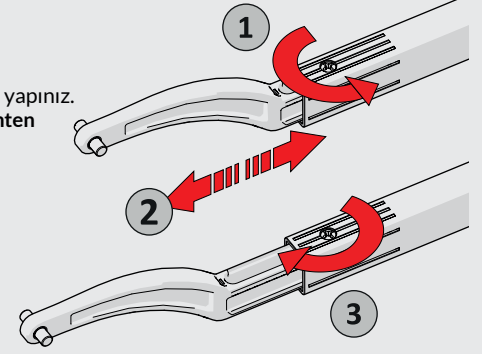

Not: Kullanım esnasında vidada gevşeme görülürse uygun pozisyona getirerek sıkınız.

Hinweis: Wenn sich die Schraube während des Gebrauchs gelockert hat, ziehen Sie sie fest, indem Sie sie in die entsprechende Position bringen.

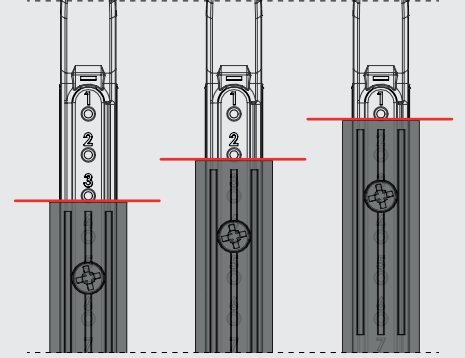

Önemli:

Doğru delik numarasını tespit etmek için kol profilinin kesitini hizalayınız.

Wichtig:

Zur Einstellung der korrekten Lochnummer bei Teleskoparmen bitte die Ausrichtung anhand der Profilkante vornehmen.

Not: Tabloda belirtilmeyen kabin yükseklikleri için bir üst satırdaki ölçüler kullanılarak montaj yapılabilir.

Hinweis: Für Schrankhöhen, die nicht in der Tabelle angegeben sind, kann der Einbau unter Verwendung der Angaben erfolgen, die in der oberen Zeile der Maßangaben aufgeführt sind, und die Ihrer Schrankhöhe am nächsten liegen.

İŞLEM SCHRITT 4

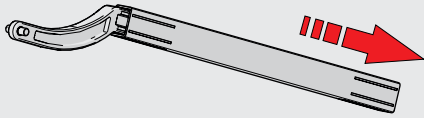

Kol profilini mekanizmaya yerleştirin.
Setzen Sie den Arm auf den Mechanismus

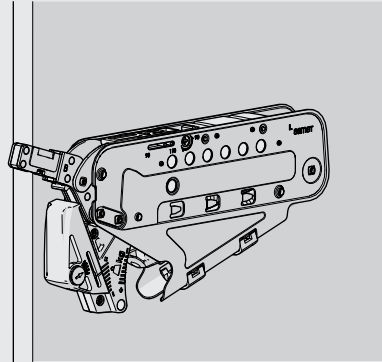

Sabitleme vidasını sıkın.
Befestigungsschraube festziehen.

Dikkat / Vorsicht

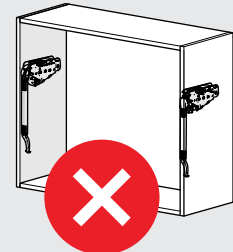
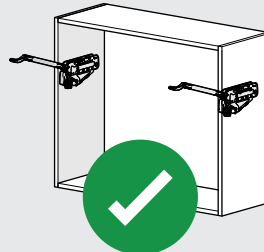
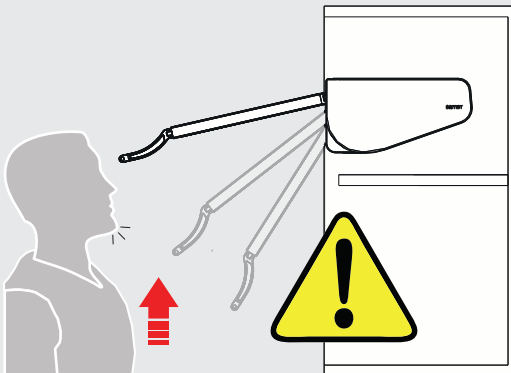

Dikkat: Mekanizma kolu yukarıya fırlayarak yaralanmalara sebep olabilir.
Achtung: Hebelarm kann hochschnellen und Verletzungen verursachen.

İŞLEM
SCHRITT 5

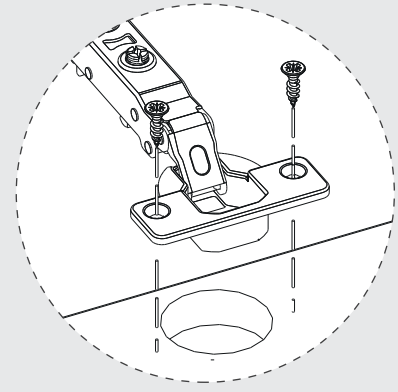
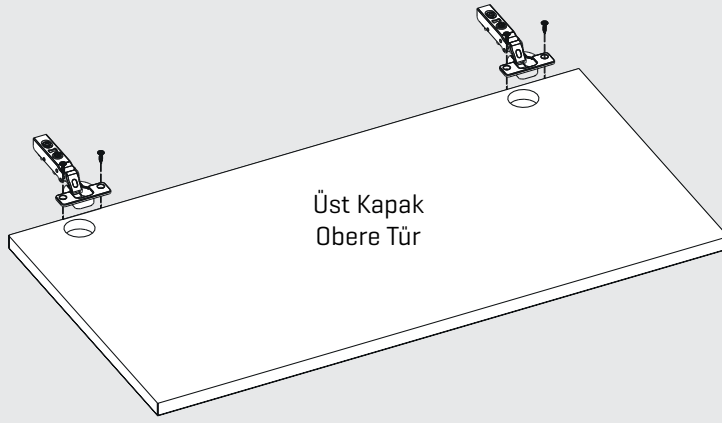

İŞLEM
SCHRITT 6

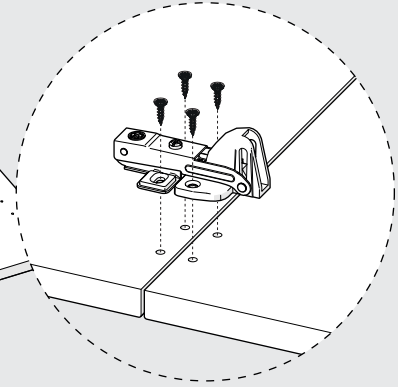
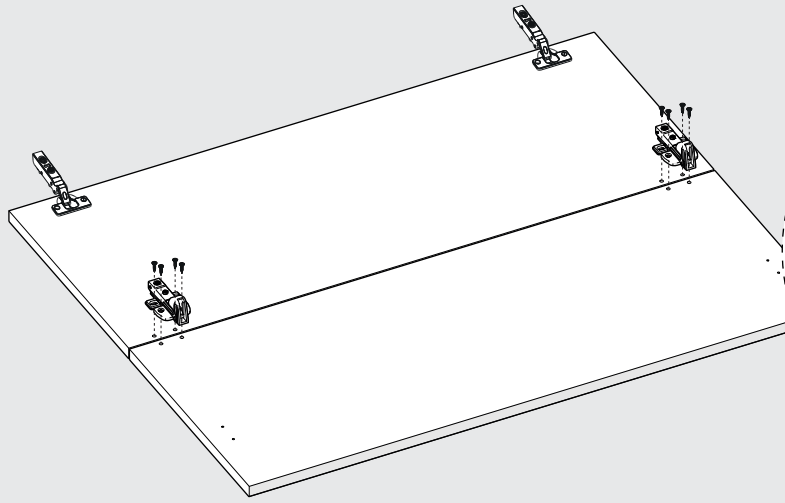

İŞLEM
SCHRITT 7

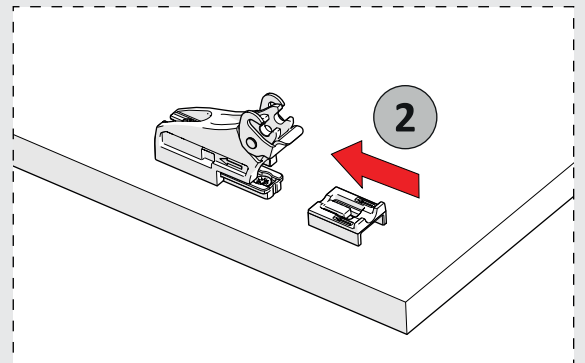
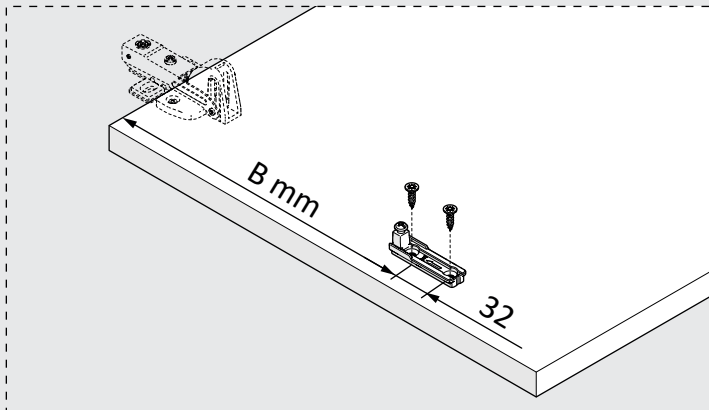
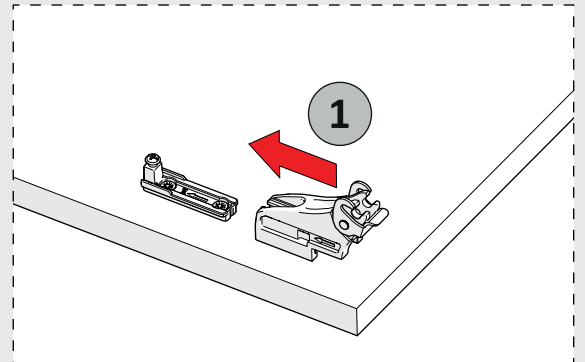
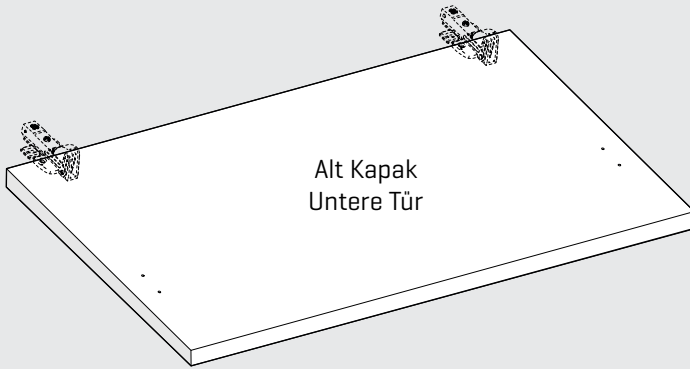

İŞLEM
SCHRITT 8

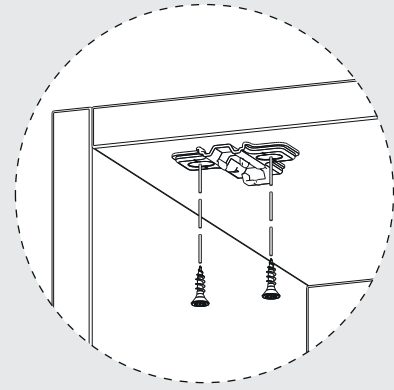
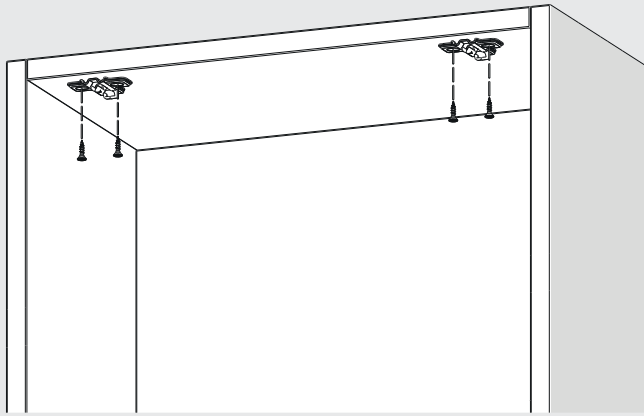

İŞLEM
SCHRITT 9

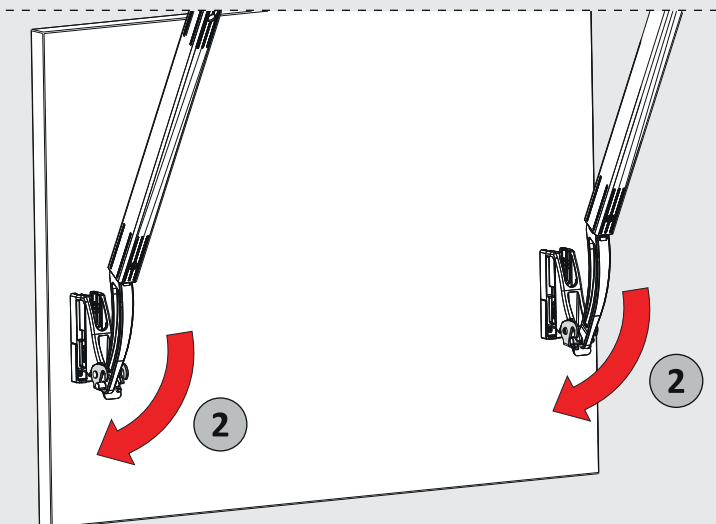
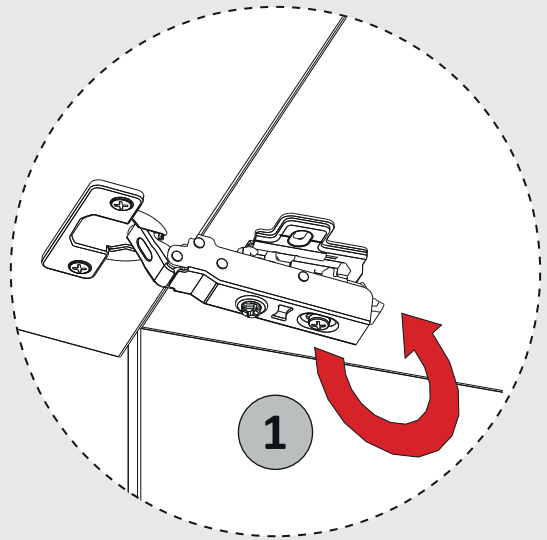
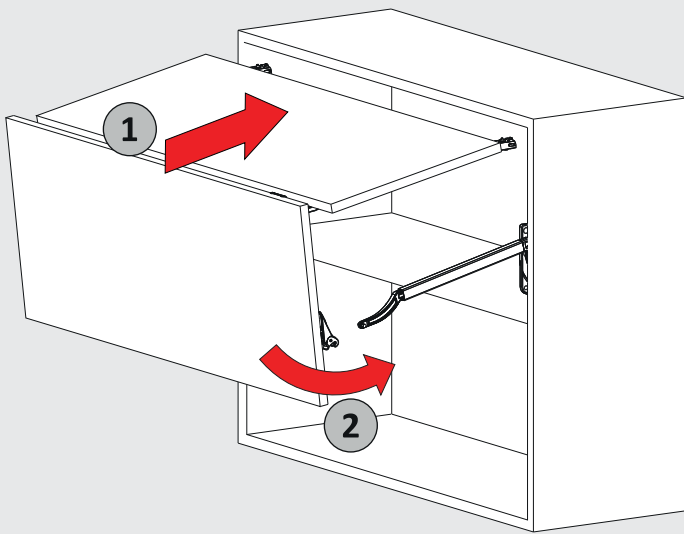

SPERRVORRICHTUNG



İŞLEM
SCHRITT 10.A

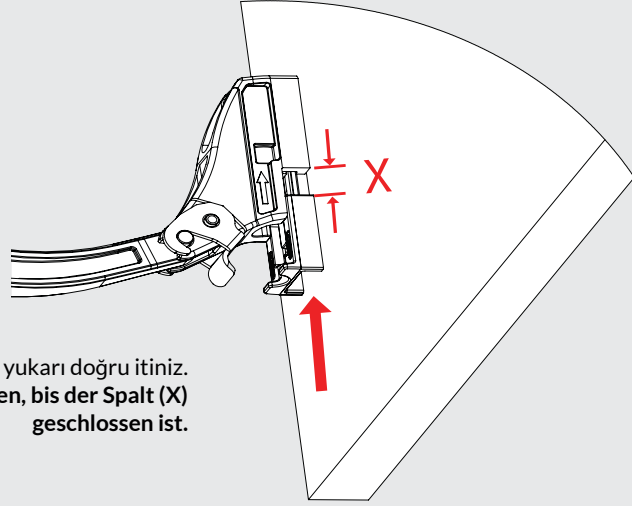

Alttaki parçayı, aralık (X) kapanıncaya kadar yukarı doğru itiniz.
Schieben Sie das Unterteil nach oben, bis der Spalt (X)
geschlossen ist.

İŞLEM
SCHRITT 10.B

Kapakları bastırarak kapatınız.
Türen durch Drücken schließen.

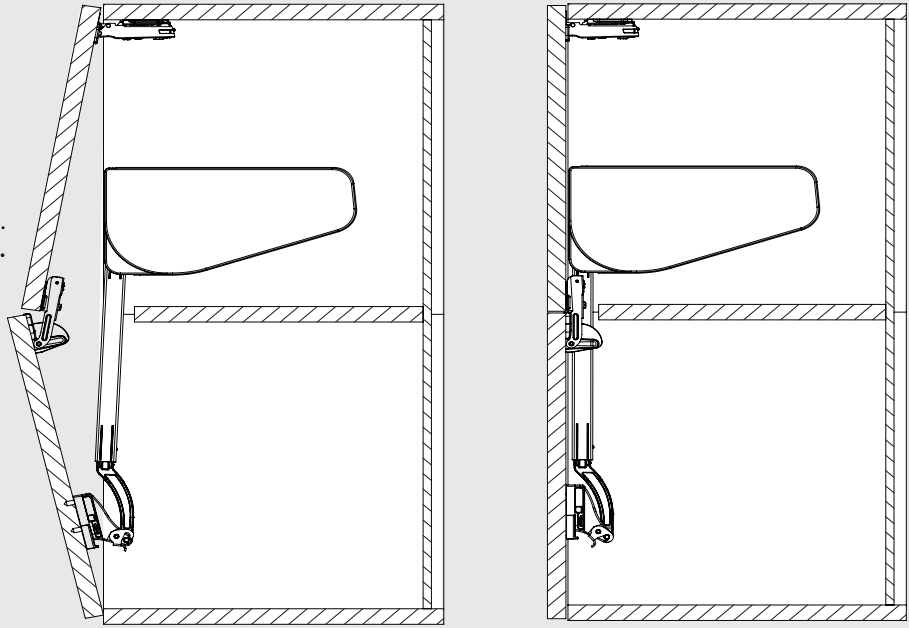

İŞLEM
SCHRITT 10.C

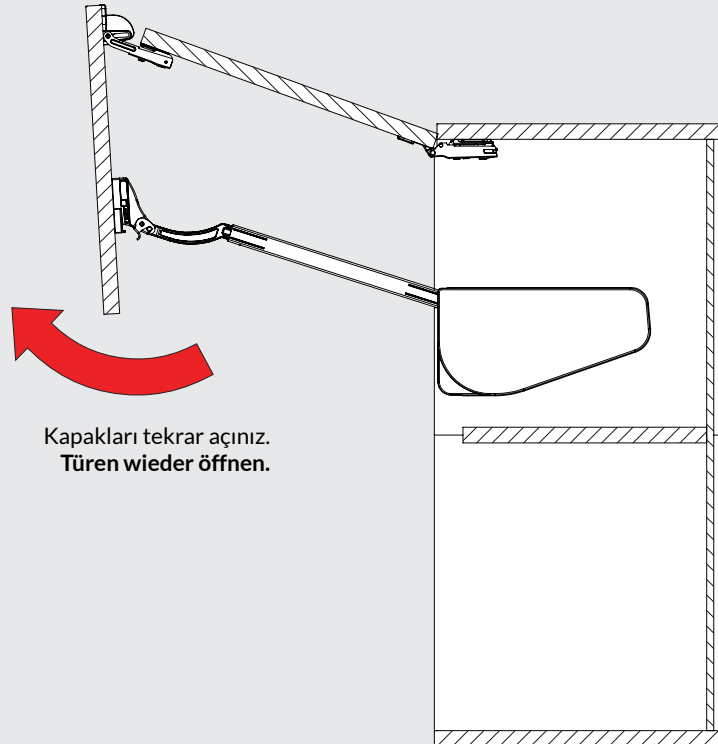

Kapakları tekrar açınız.
Türen wieder öffnen.

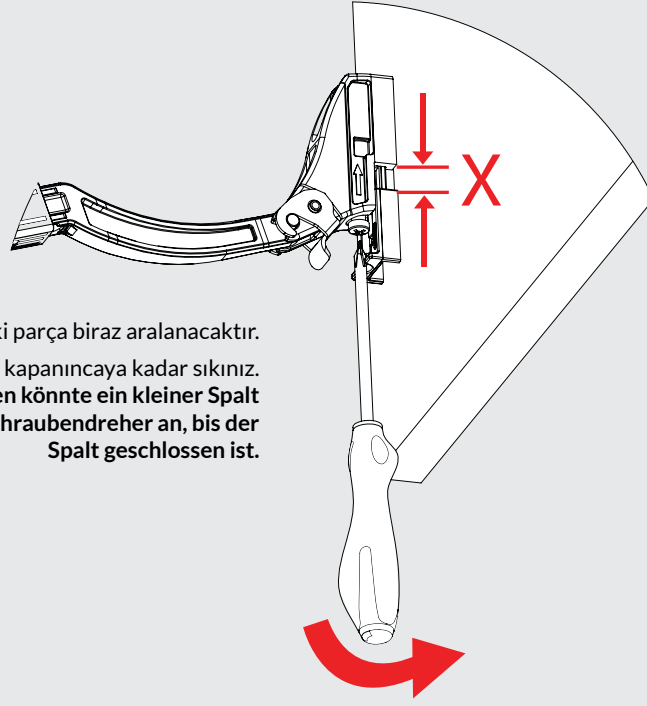
İŞLEM
SCHRITT **10.D**

Bu iki parça biraz aralanacaktır.
Vidayı tornavida ile aralık kapanıncaya kadar sıkınız.
Zwischen diesen beiden Kunststoffteilen könnte ein kleiner Spalt sein. Ziehen Sie die Schraube mit einem Schraubendreher an, bis der Spalt geschlossen ist.

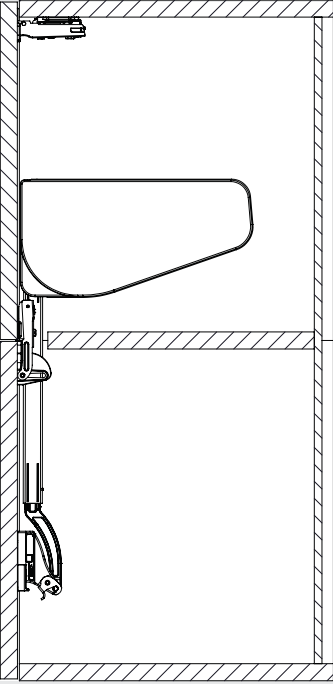
İŞLEM
SCHRITT **10.E**

Kapakları tekrar kapatın, ayarın tamamlandığını göreceksiniz.
Schließen Sie die Türen erneut. Bei diesem Schritt muss die Armjustierung durchgeführt worden sein.

İŞLEM
SCHRITT **10.F**

Kapakları tekrar açınız.
Türen wieder öffnen.

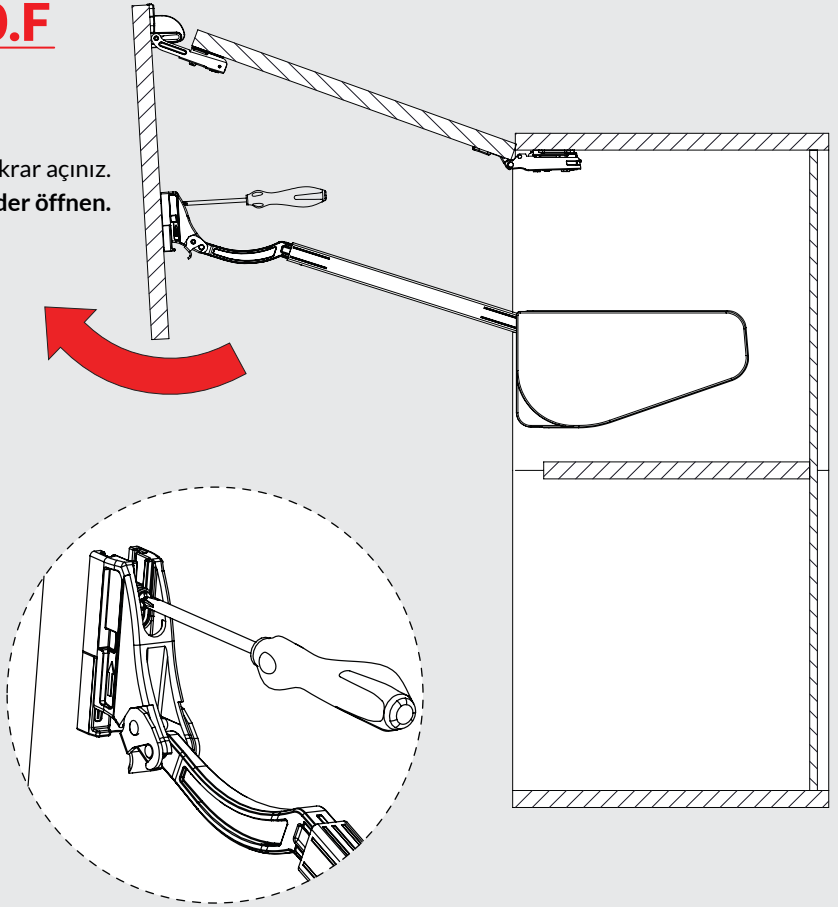

Yapılan ayarı sabitlemek için vidayı tornavida ile sıkınız.
Achten Sie darauf, die Schraube mit einem Schraubendreher fest anzuziehen, um die Armeinstellung zu fixieren.

Üst Mentеше / Oberes Scharnier

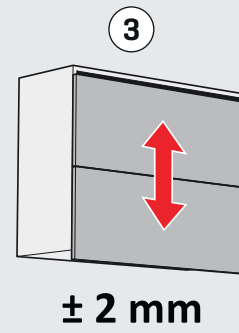
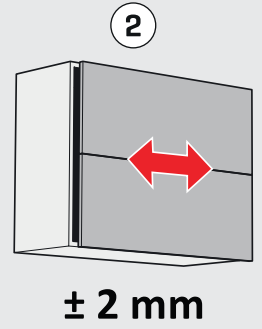
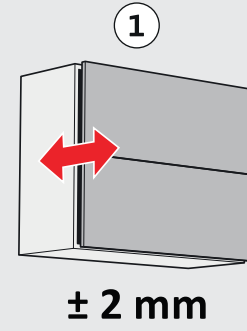
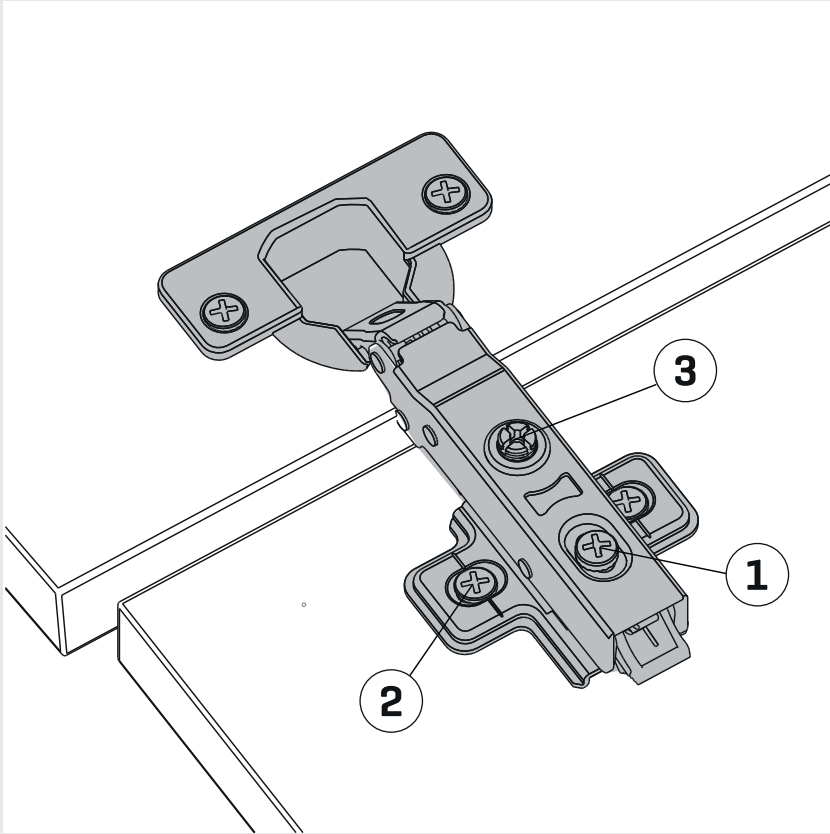

Ara Mentеше / Mittleres Scharnier

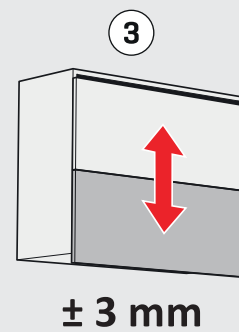
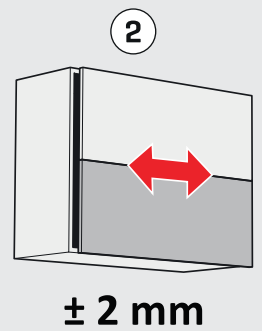
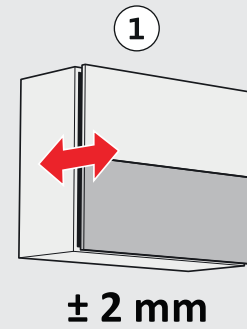
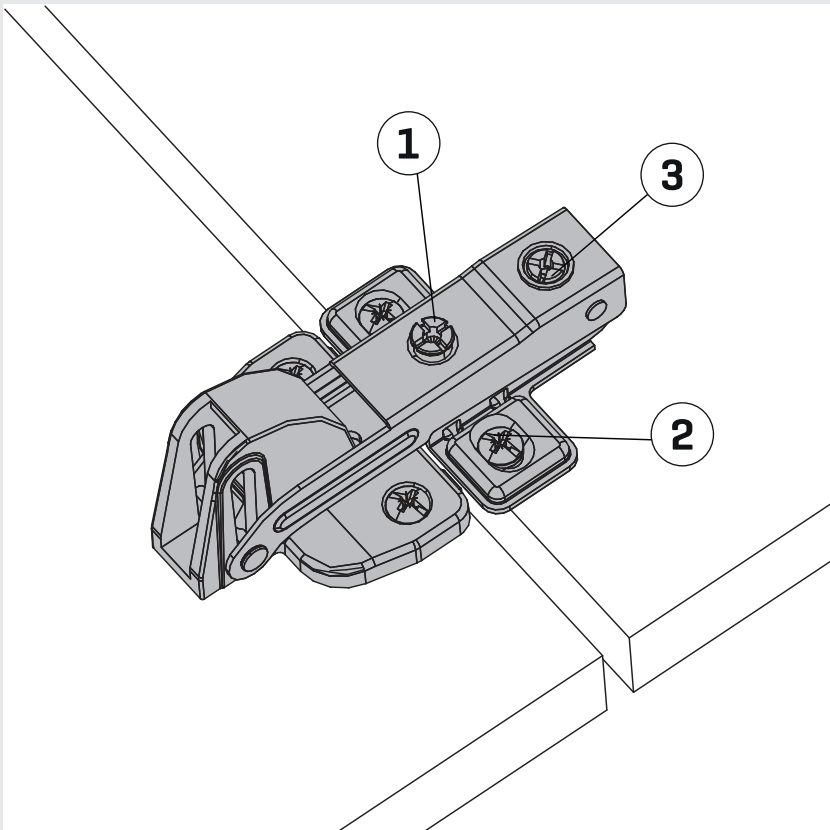

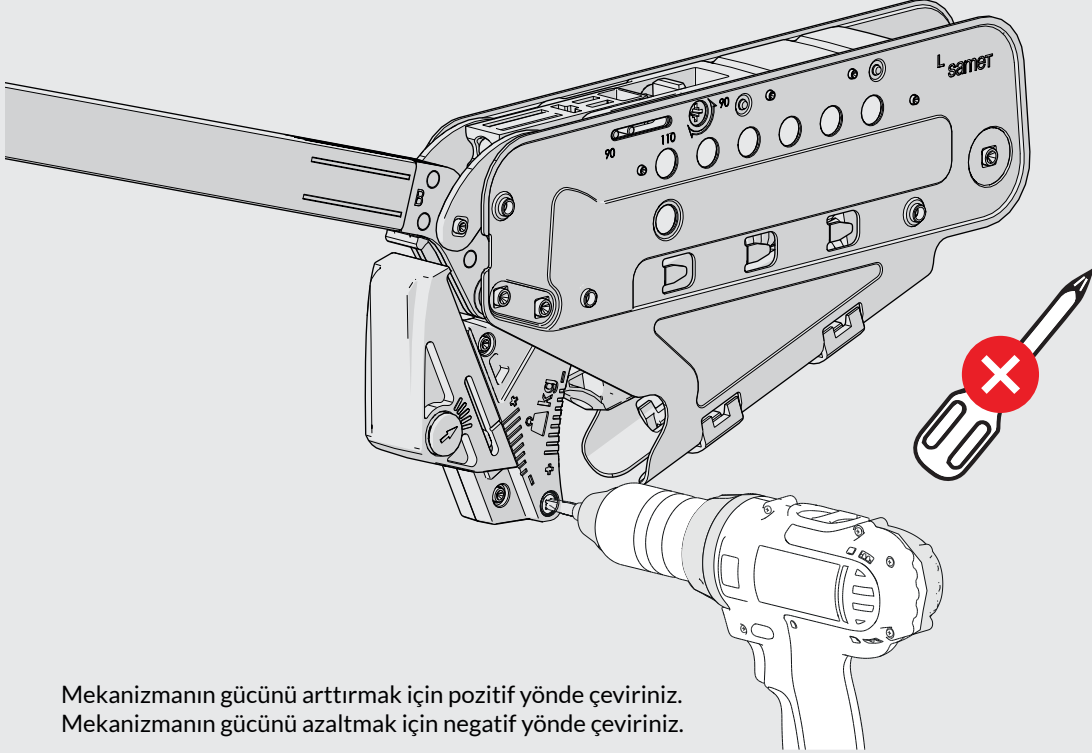

Mekanizmanın gücünü arttırmak için pozitif yönde çeviriniz.
Mekanizmanın gücünü azaltmak için negatif yönde çeviriniz.

Um die Belastbarkeit des Mechanismus zu erhöhen, nehmen Sie bitte die Einstellung in positiver Richtung vor.
Um die Belastbarkeit des Mechanismus zu verringern, nehmen Sie bitte die Einstellung in negativer Richtung vor.

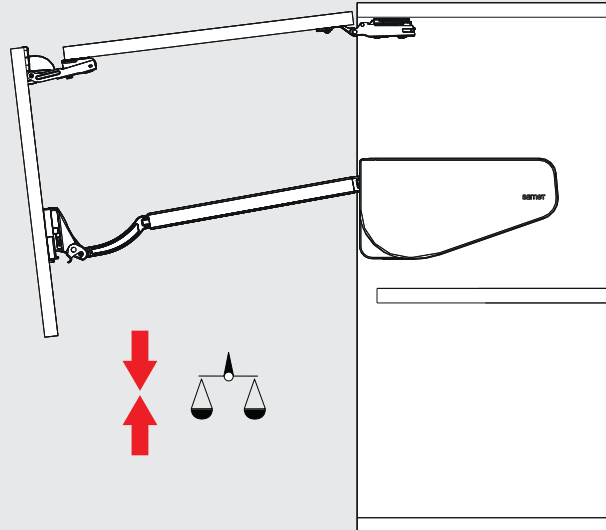

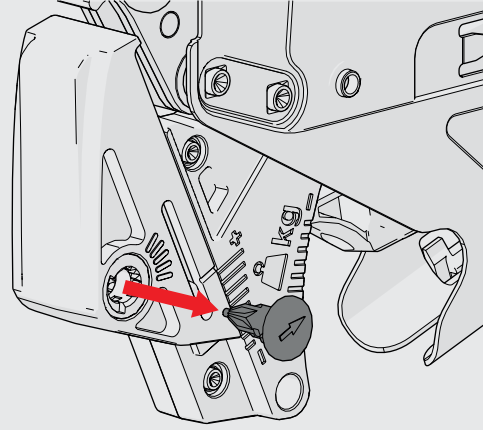
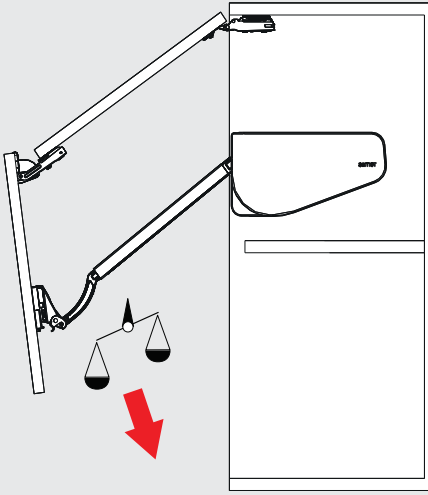

- 1** Damper emniyet pimini çıkarınız.
Nehmen Sie den Sicherungsstift des Dämpfers heraus.

**UYARI
WICHTIG**



Şarjlı matkap ile ayar yapmayınız.
Nehmen Sie die Einstellung nicht mit einem
Akkuschrauber oder einer Akkubohrmaschine vor.

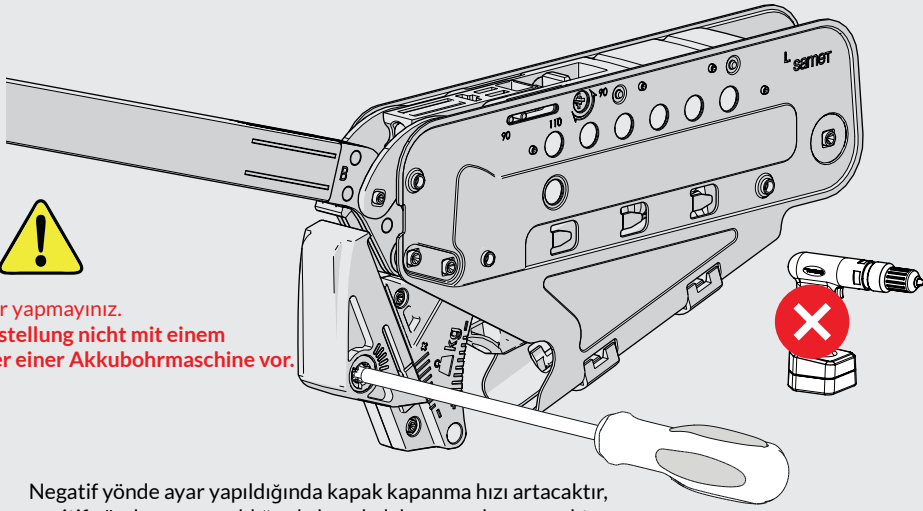

Negatif yönde ayar yapıldığında kapak kapanma hızı artacaktır,
pozitif yönde ayar yapıldığında kapak daha yavaş kapanacaktır.

2

Die Einstellung in negativer Richtung sorgt für einen schnelleren Türschließeffect, die
Einstellung in positiver Richtung für einen langsameren Türschließeffect.

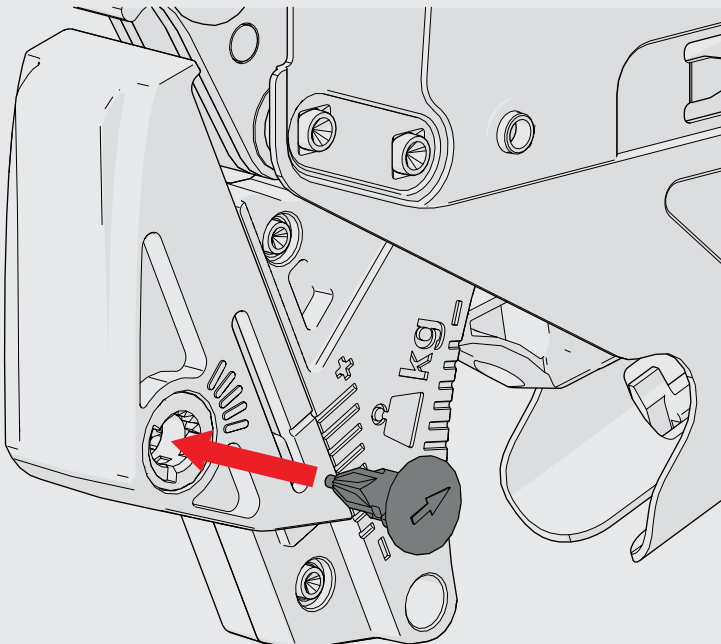

- 3** Damper emniyet pimini takınız.
Setzen Sie den Sicherungsstift des Dämpfers ein.



Damper emniyet pimini takarken işaretli alan içerisinde kalacak
şekilde uygun yerden takınız.

Bitte beachten Sie das Pfeilzeichen zum Anbringen des
Dämpfersicherungsstiftes.

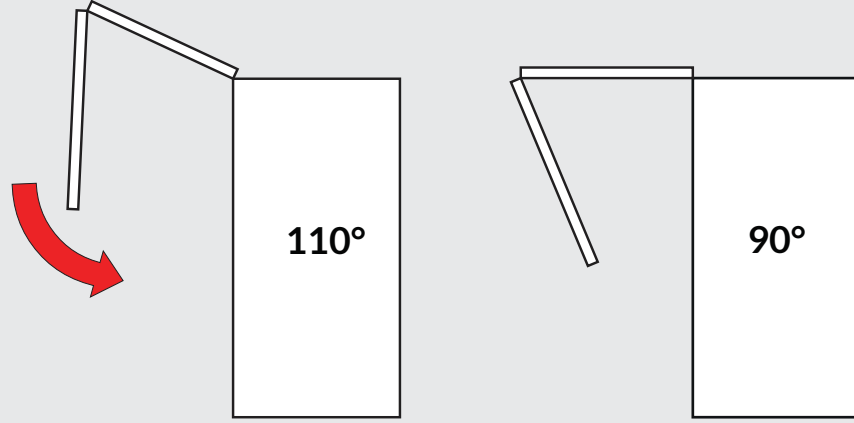

90 derece açılma açısı için öncelikle kapağı 90 derecenin altına gelecek şekilde indiriniz ve tornavida ile ok yönlerine doğru çevirerek kapağın açılma açısı için pimlerin tercih edilen açığa gelmesini sağlayınız.

Bitte achten Sie darauf, die Stifte auf den gewünschten Öffnungswinkel zu setzen.
Für eine 90-Grad-Öffnung senken Sie die Türen bitte unter den 90-Grad-Winkel ab und drehen dann die Schraube in Richtung 90-Grad.
Für eine 110-Grad-Öffnung drehen Sie bitte die Schraube in Richtung 110-Grad.

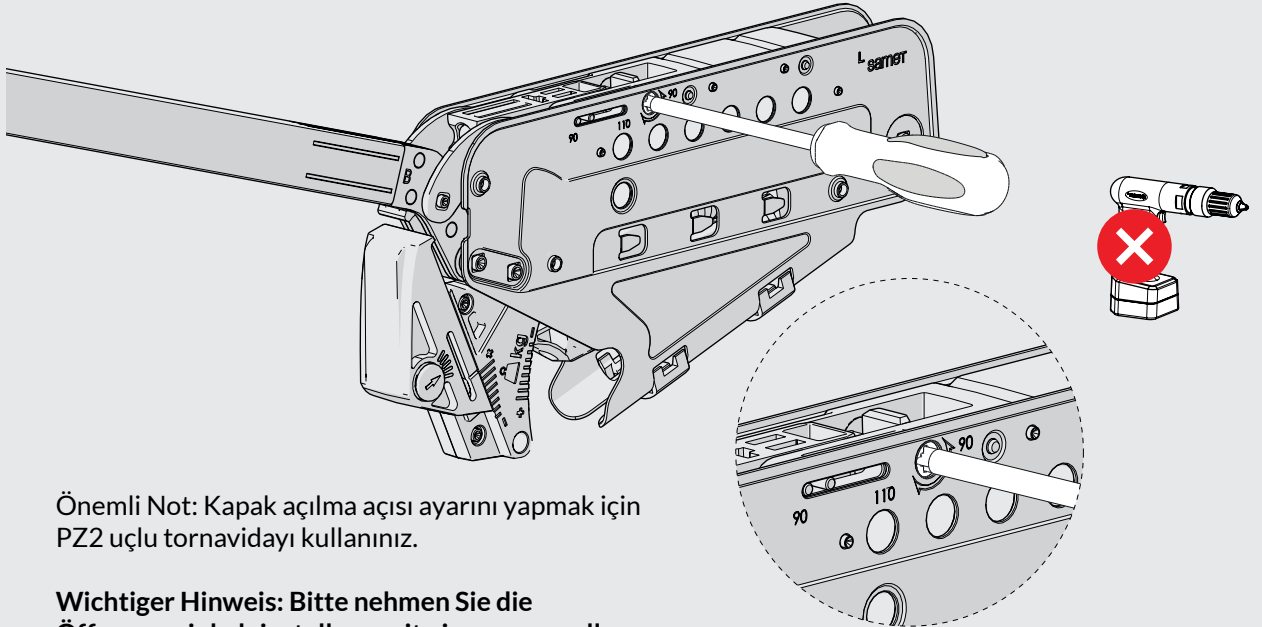

Önemli Not: Kapak açılma açısı ayarını yapmak için PZ2 uçlu tornavidayı kullanınız.

Wichtiger Hinweis: Bitte nehmen Sie die Öffnungswinkeleinstellung mit einem manuellen Schraubendreher mit Pozi-Drehspitze #2 vor.

ALÜMİNYUM KAPAK UYGULAMASI
ALUMINIUMTÜR-ANWENDUNG

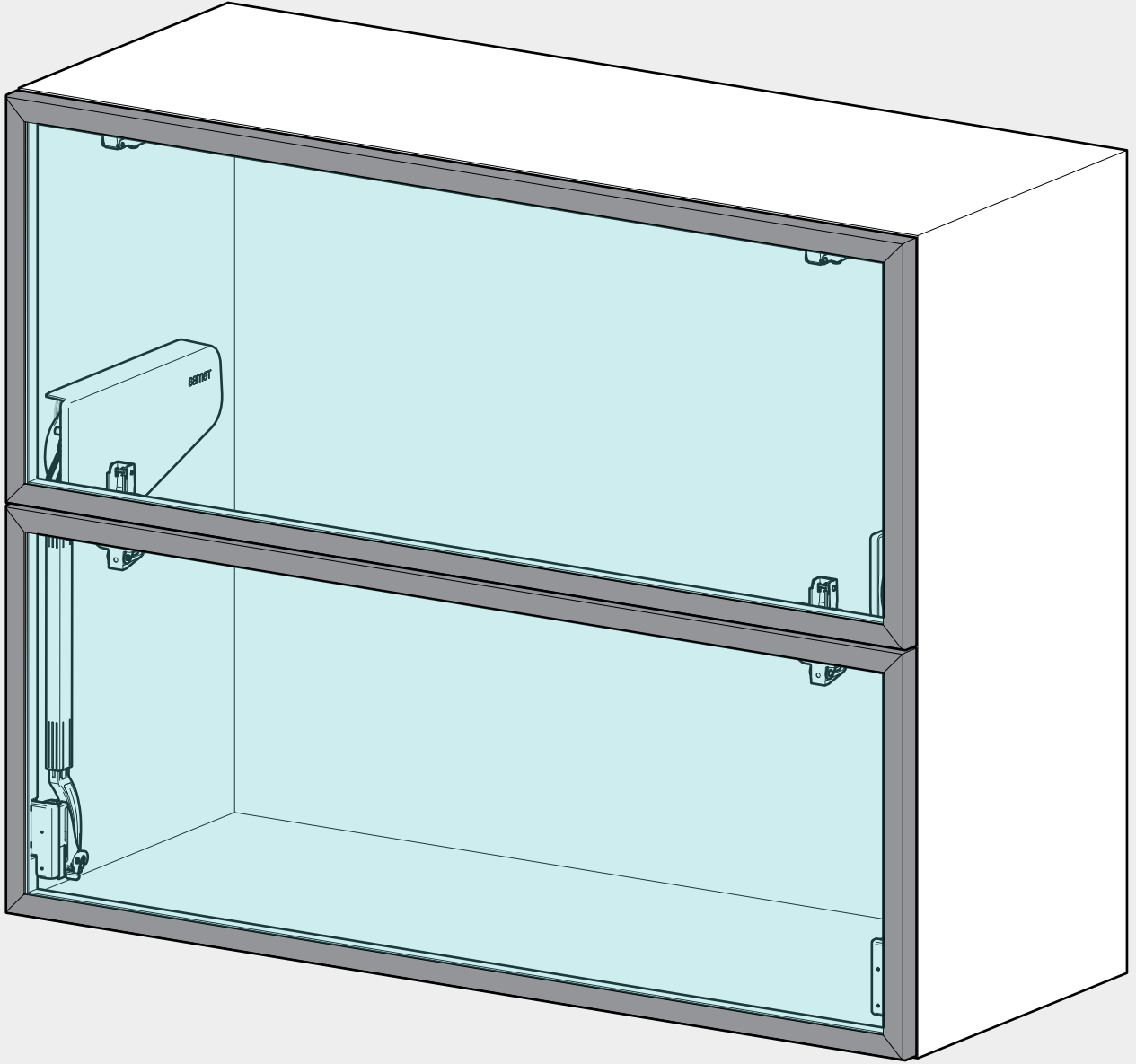

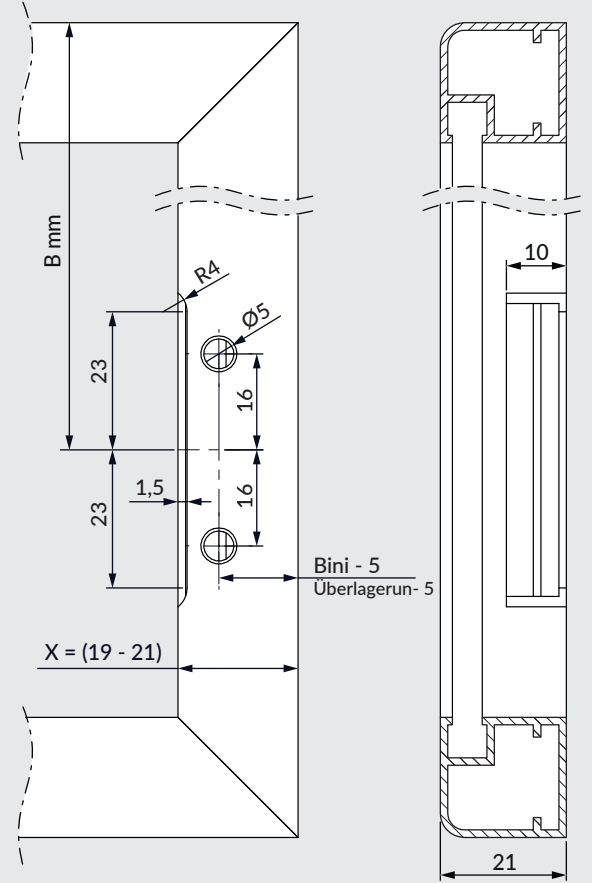
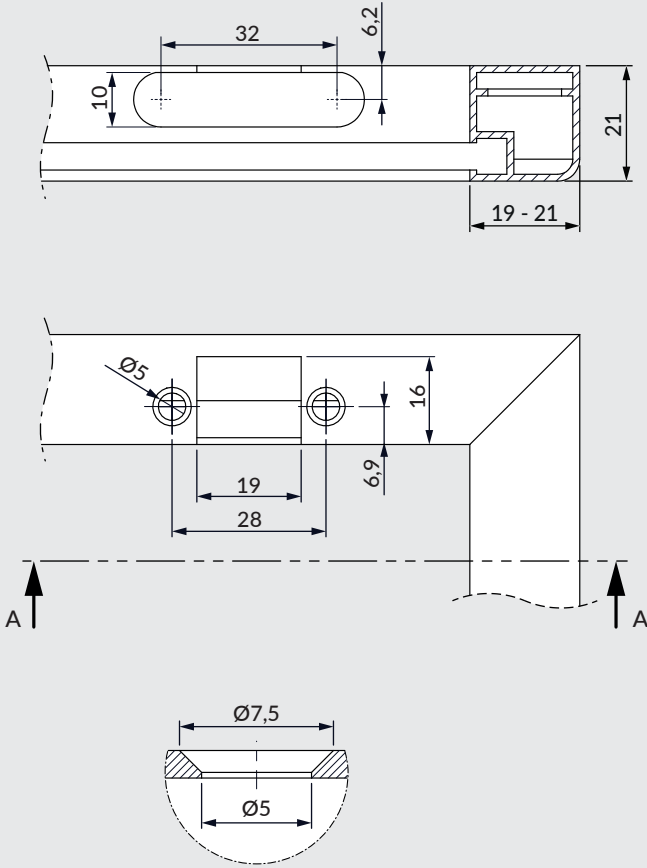
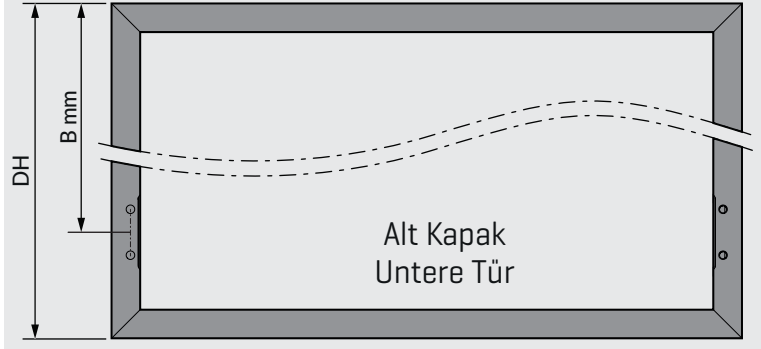
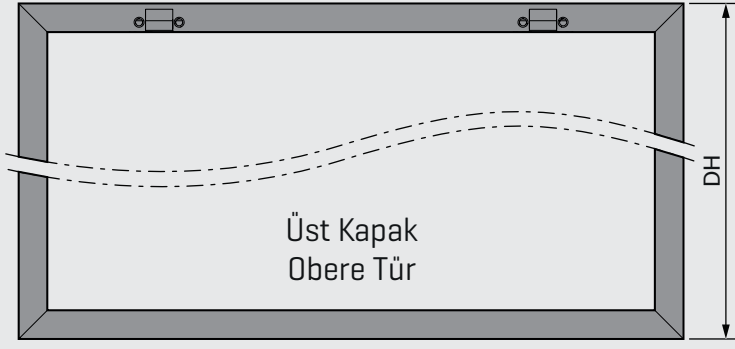

Tek Raf Uygulaması Einzelregal-Anwendung	
Kabin Yüksekliği Schrankschöhe (mm)	B mesafesi Abstand B (mm)
1040	383
1000	366
900	310
860	302
800	258
760	242
720	218
700	210
650	185
600	160
560	143
500	112
480	105

Simetrik İki Raf Uygulaması Symmetrische Doppelregal-Anwendung	
Kabin Yüksekliği Schrankschöhe (mm)	B mesafesi Abstand B (mm)
900	361
800	310
720	282

DH: Kapak Yüksekliği - Türhöhe

Not: Tabloda belirtilmeyen kabin yükseklikleri için bir üst satırdaki ölçüler kullanılarak montaj yapılabilir.

Hinweis: Für Schrankhöhen, die nicht in der Tabelle angegeben sind, kann der Einbau unter Verwendung der Angaben erfolgen, die in der oberen Zeile der Maßangaben aufgeführt sind, und die Ihrer Schrankhöhe am nächsten liegen.

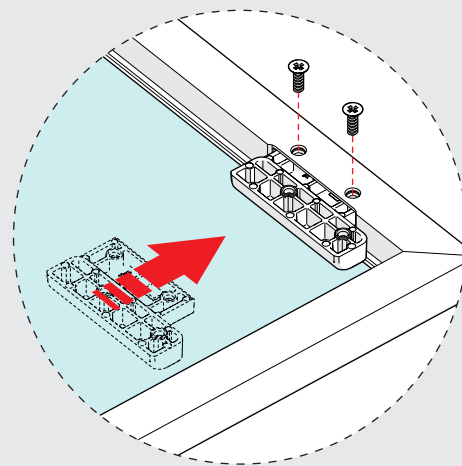
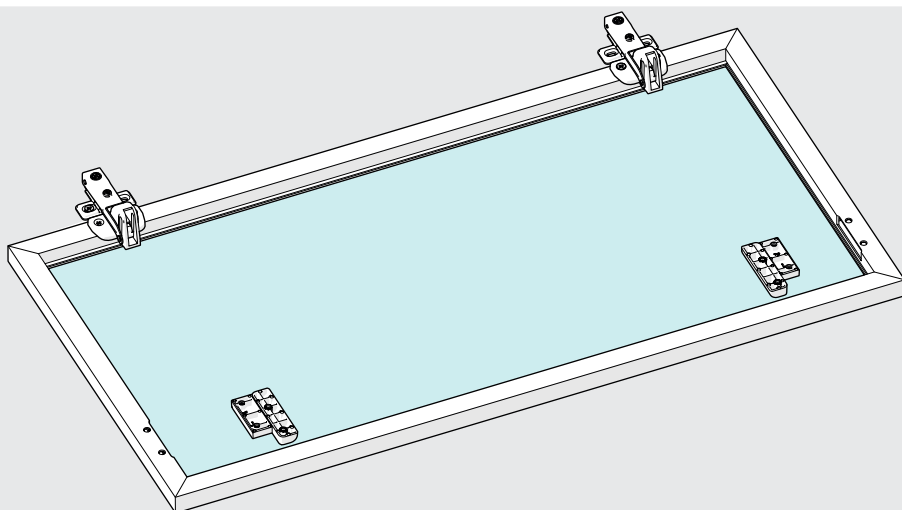
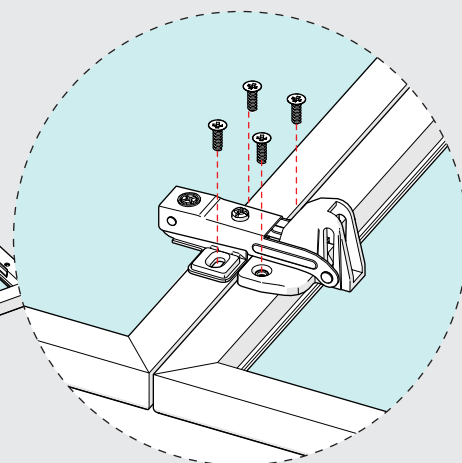
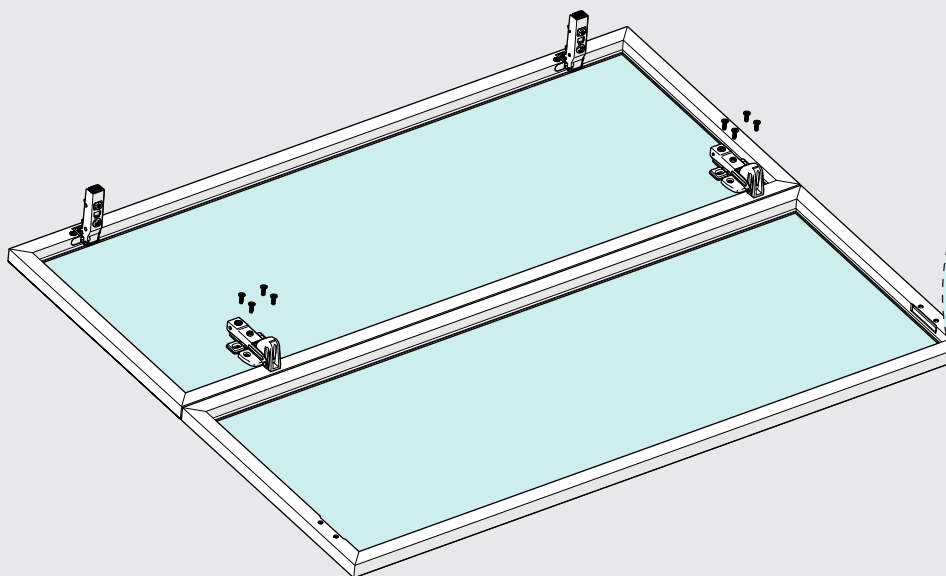
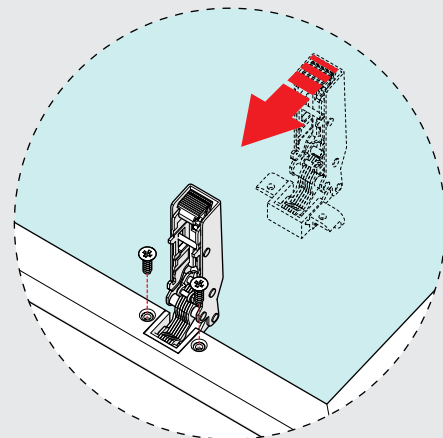
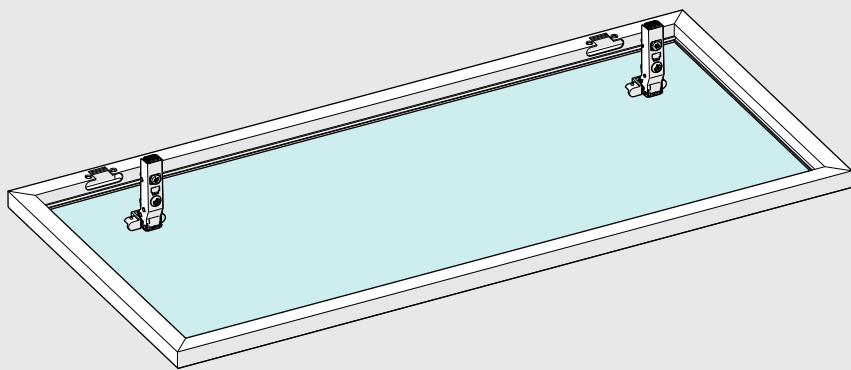

1

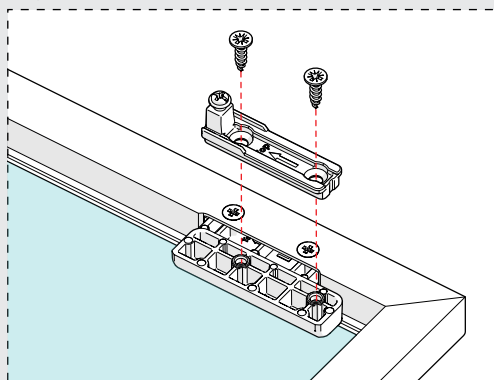

2

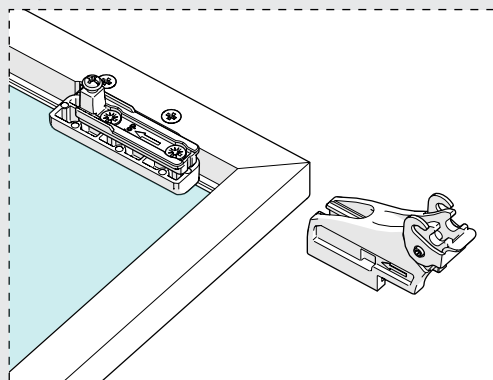

3

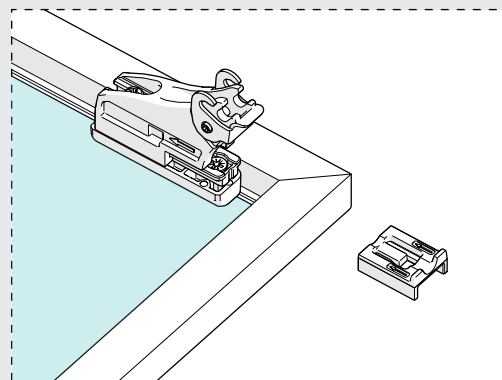

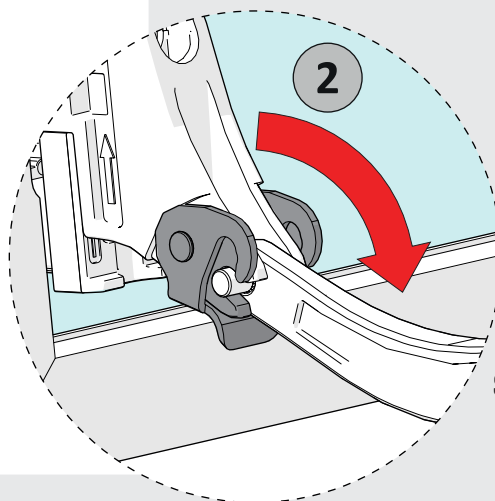
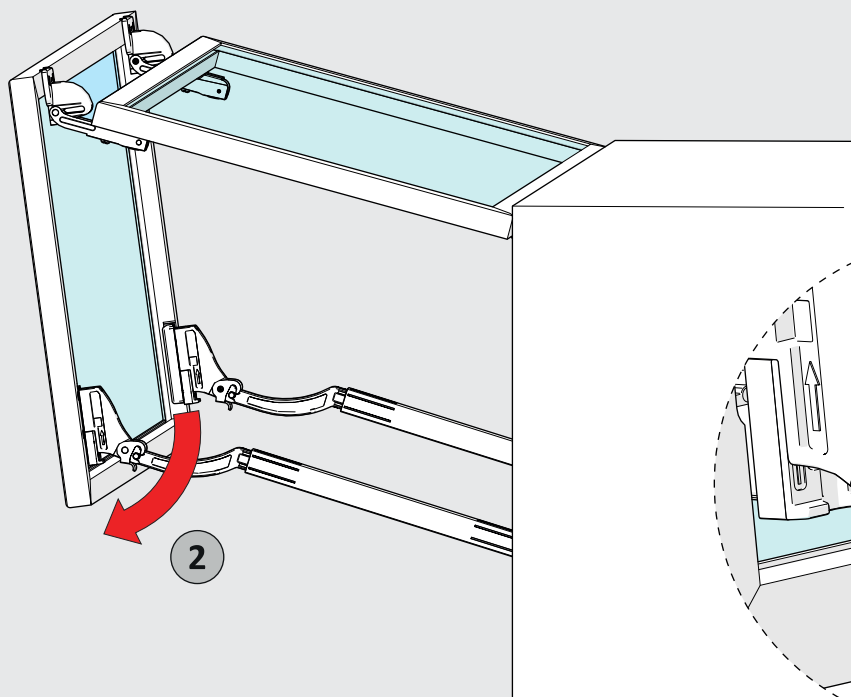
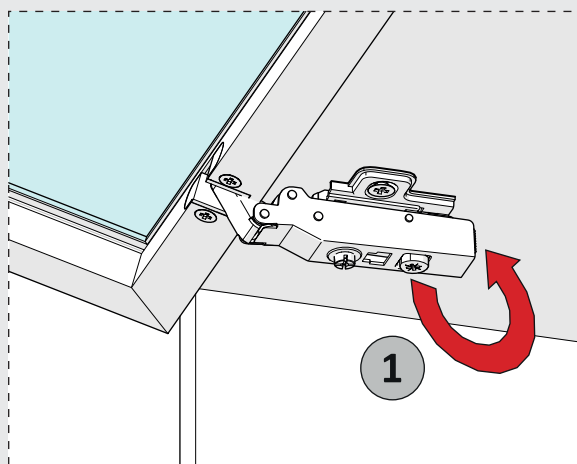
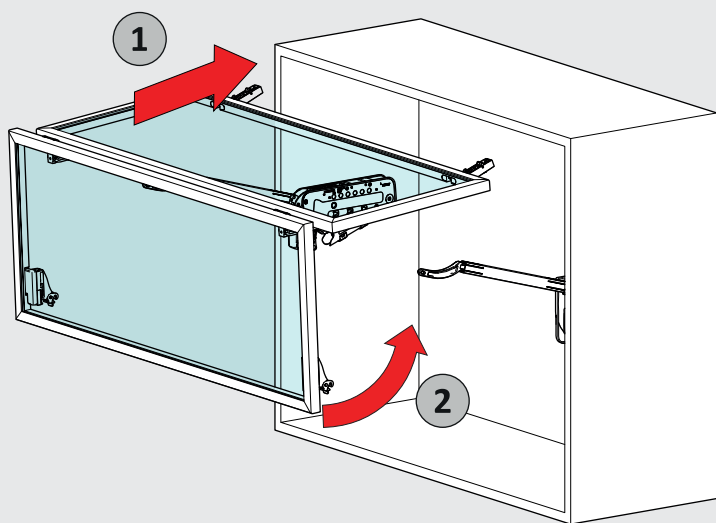
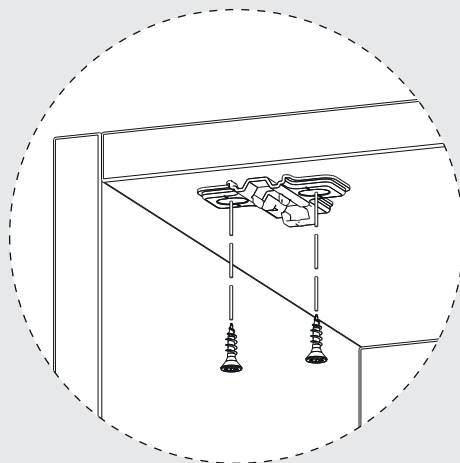
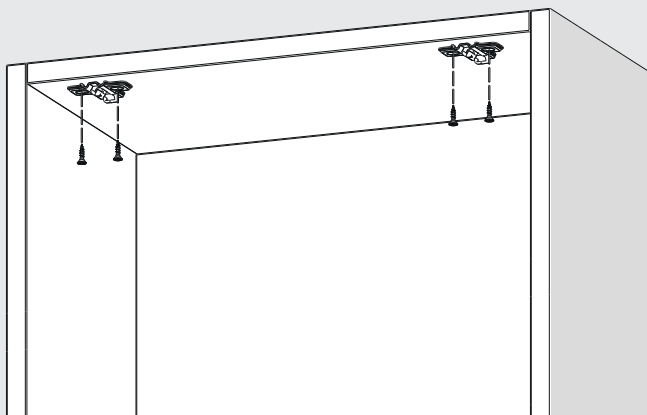

SPERRVORRICHTUNG

samet

