

Kabin Ölçüleri / Cabinet Dimensions

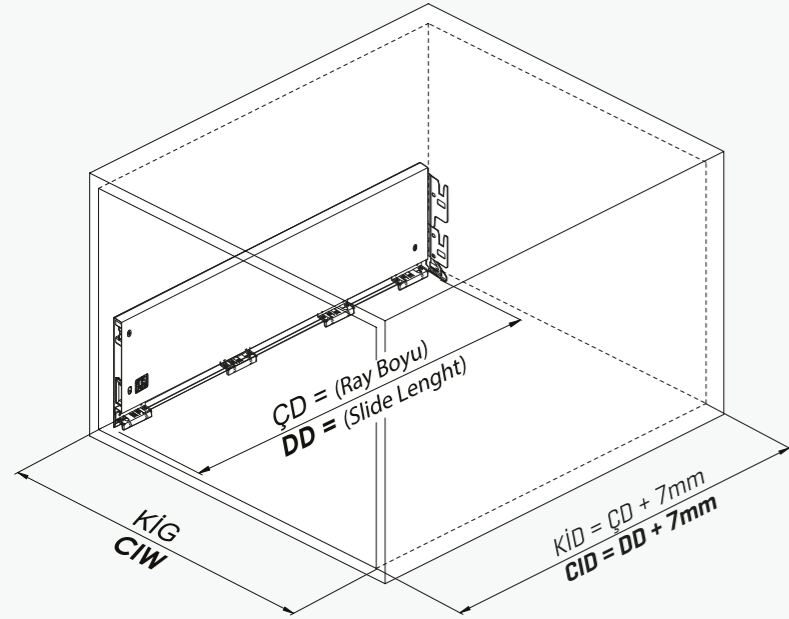

Rayların Vida Konum Ölçüleri / Screw Location for the Slides

Rayı, koyu renk ile işaretlenmiş deliklerden vidalayınız.
Screw the slide from marked holes.

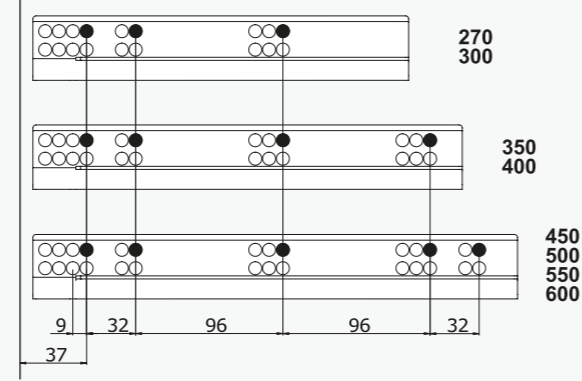

Parçalar / Parts

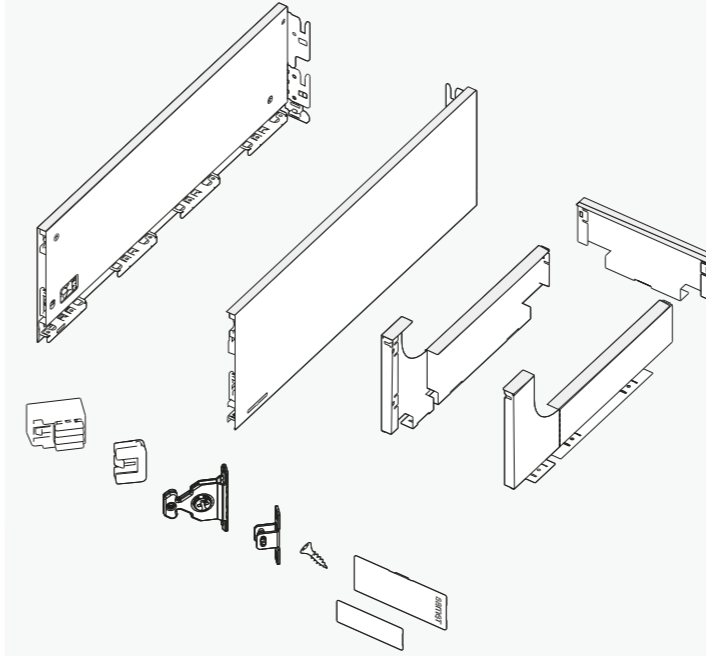

Bordürlü Ön Panel & Bağlantı Parçası Without Gallery Railing Front Panel & Connection Pieces

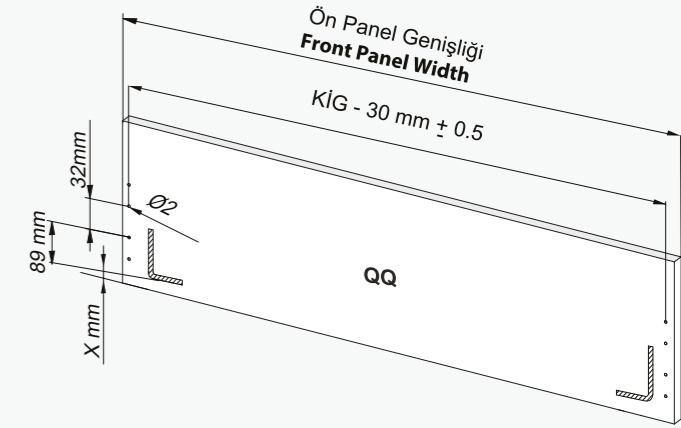

Rayların Vida Konum Ölçüleri / Screw Location for the Slides

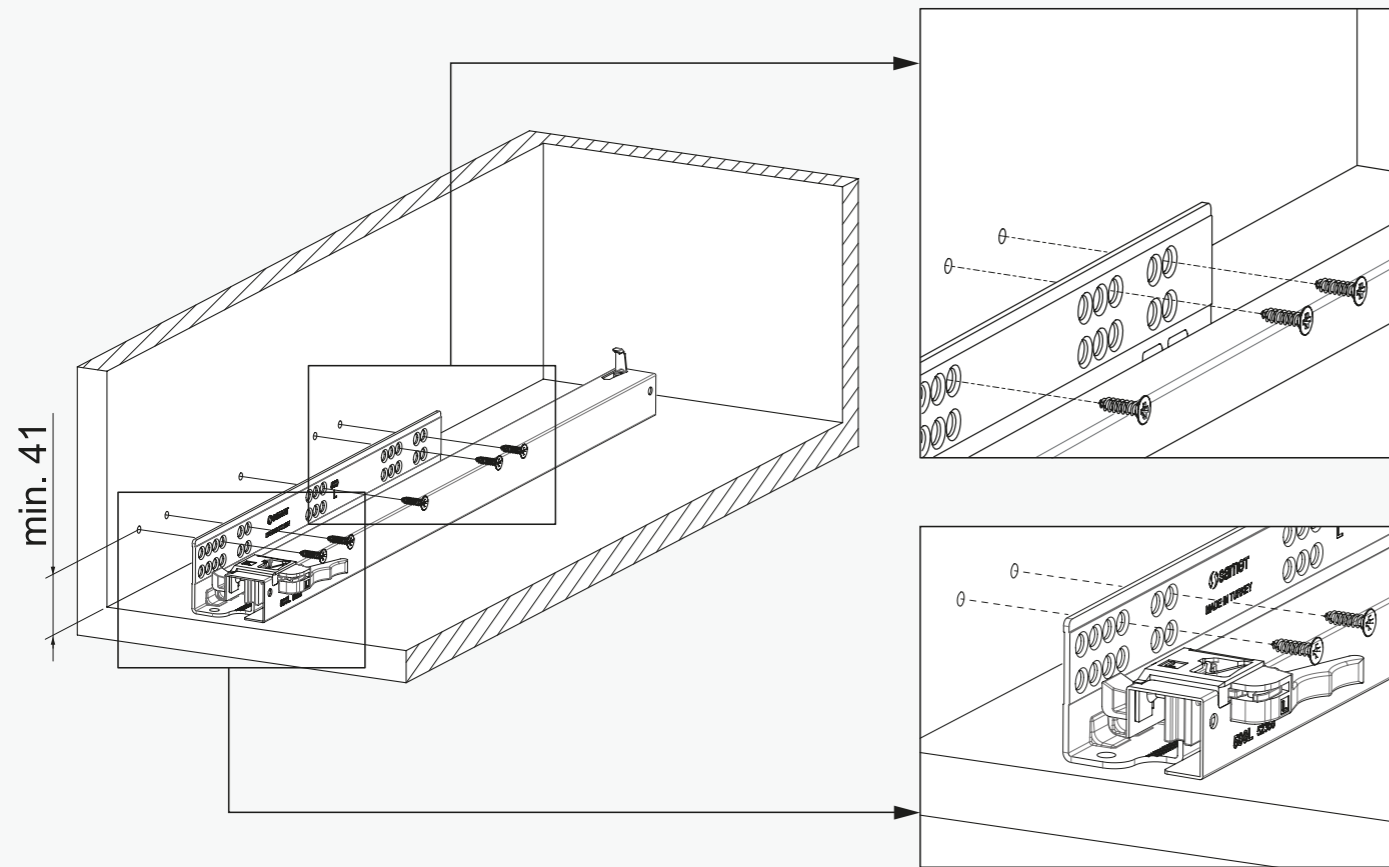

Teknik Ölçüler / Technical Dimensions

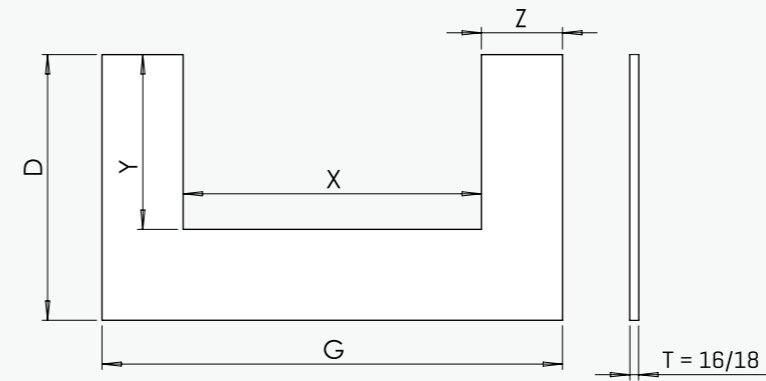

T = Sipariş sırasında belirlenen taban tahtası kalınlığı.
Base panel thickness that is determined while ordering.

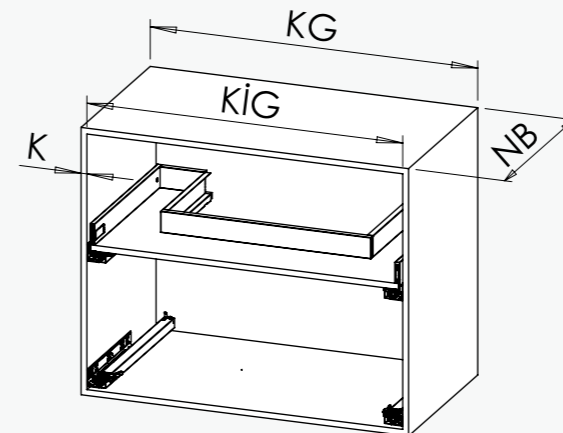

K = 16mm	KG:450	KG:600	KG:900	KG:1200
NB:350	X:160 Y:243 Z:117,5 D:338 G:396	X:160 Y:243 Z:192,5 D:338 G:546	X:160 Y:243 Z:342,5 D:338 G:846	X
NB:450	X:160 Y:243 Z:117,5 D:438 G:396	X:160 Y:243 Z:192,5 D:438 G:546	X:547 Y:271 Z:149 D:438 G:846	X
NB:500	X:160 Y:243 Z:117,5 D:488 G:396	X:160 Y:243 Z:192,5 D:488 G:546	X:547 Y:321 Z:149 D:488 G:846	X:547 Y:321 Z:299 D:488 G:1146
K = 18mm	KG:450	KG:600	KG:900	KG:1200
NB:350	X:156 Y:243 Z:117,5 D:338 G:392	X:156 Y:243 Z:192,5 D:338 G:542	X:156 Y:243 Z:342,5 D:338 G:842	X
NB:450	X:156 Y:243 Z:117,5 D:438 G:392	X:156 Y:243 Z:192,5 D:438 G:542	X:543 Y:271 Z:149 D:438 G:842	X
NB:500	X:156 Y:243 Z:117,5 D:488 G:392	X:156 Y:243 Z:192,5 D:488 G:542	X:543 Y:321 Z:149 D:488 G:842	X:543 Y:321 Z:299 D:488 G:1142

Montaj / Assembly

