

Wymiary szuflady i szafki

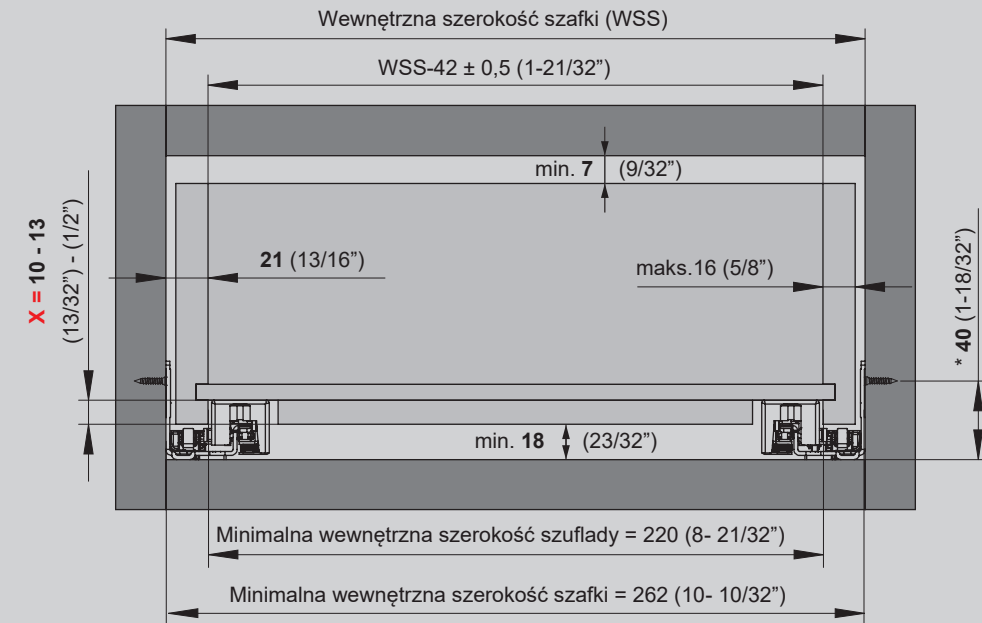

W przypadku szafek bezramowych minimalna odległość środka wkrętu powinna wynosić (*) min. 42 mm (1-21/32\"/>

Przygotowanie tylnej części szuflady

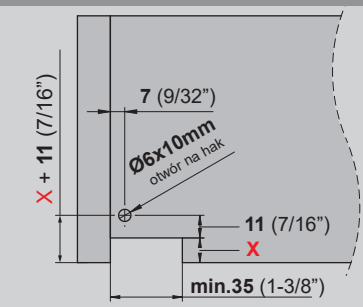

X = 10 - 13mm
X = (13/32\"/>

Tyłny wspornik montażowy

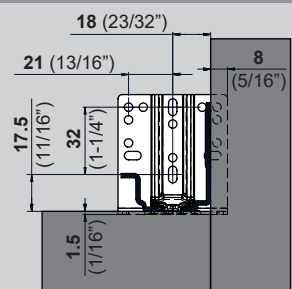

Uwaga: Stosować co najmniej trzy wkręty na wspornik.

Dane montażowe prowadnicy

Zgodność z tylnymi metalowymi wspornikami montażowymi.

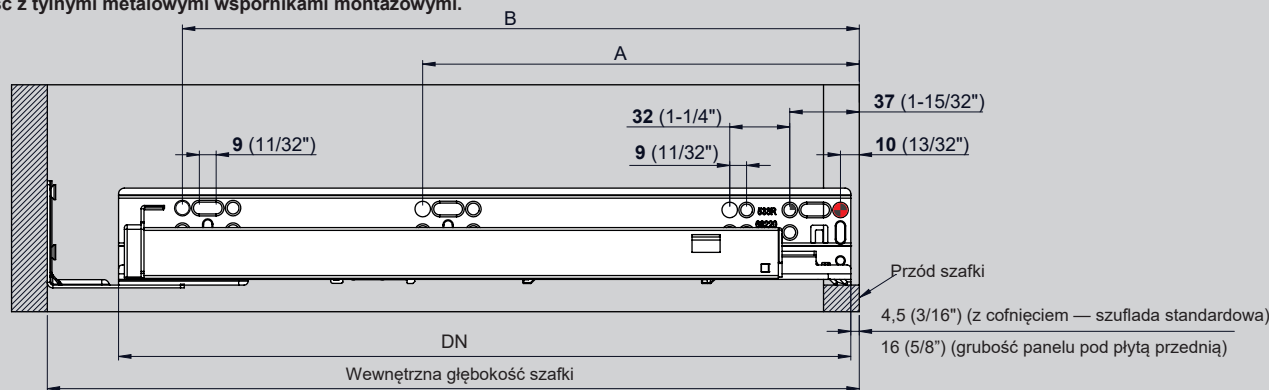

Długość szuflady	Wewnętrzna głębokość szafki z mocowaniem tylnym		Długość prowadnicy (DN)	Rozmieszczenie wkrętów dla szafek bezramowych	
	Maks.	Min.		A	B
229 (9\"/>					

Cofnięcie ślizgu dla szuflady standardowej (Zob. tabela szuflad standardowych)

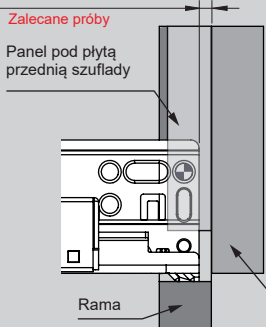

Cofnięcie ślizgu dla szuflady wpuszczanej (Zob. tabela szuflad wpuszczanych)

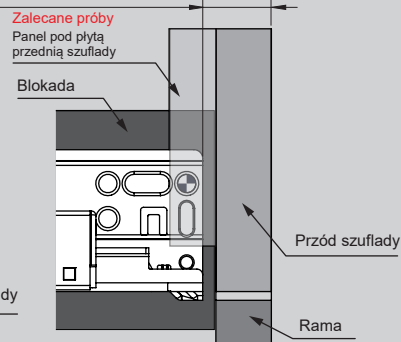

Szuflada standardowa		Cofnięcie
Grubość panelu pod płytą przednią	13 (1/2\"/>	

Szuflada wpuszczana		Cofnięcie			
Grubość panelu pod płytą przednią	13 (1/2\"/>				

Tabela konwersji milimetrów na cale

1	1.5	2	3	4	5	5.5	6	7	8	9	9.5	10	11	12	13	13.5	14	15	16	17	17.5	18	19	20	20.5	21	22	23	24	24.5	25.4
1/32	1/16	3/32	1/8	5/32	3/16	7/32	1/4	9/32	5/16	11/32	3/8	13/32	7/16	15/32	1/2	17/32	9/16	19/32	5/8	21/32	11/16	23/32	3/4	25/32	13/16	27/32	7/8	29/32	15/16	31/32	1

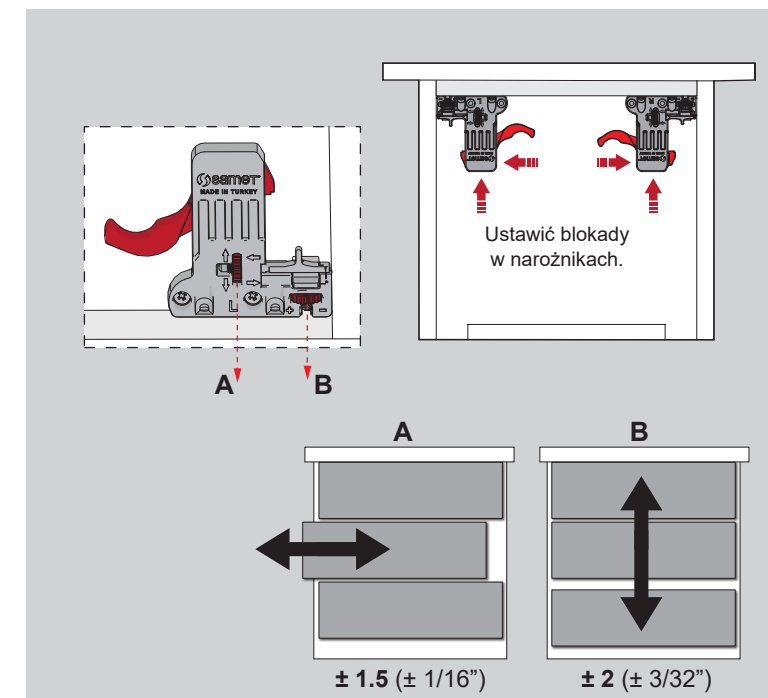
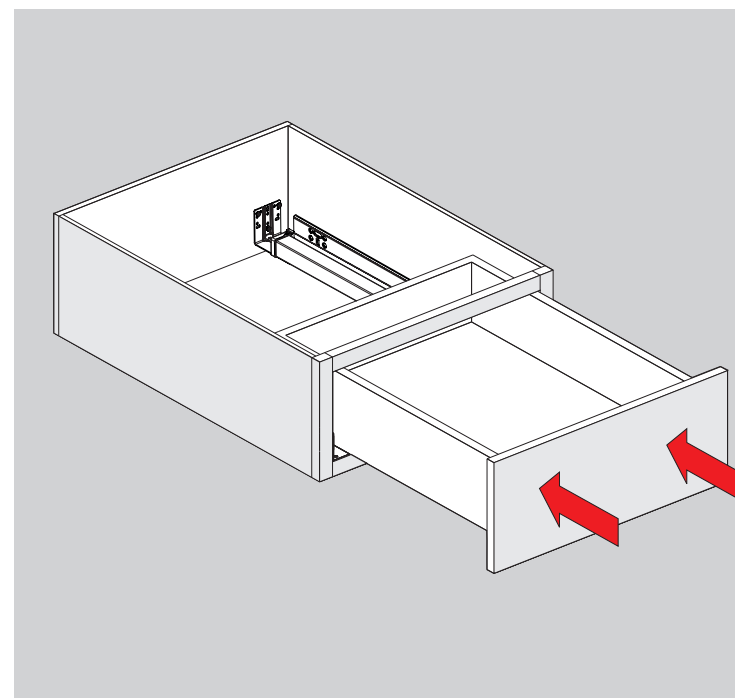
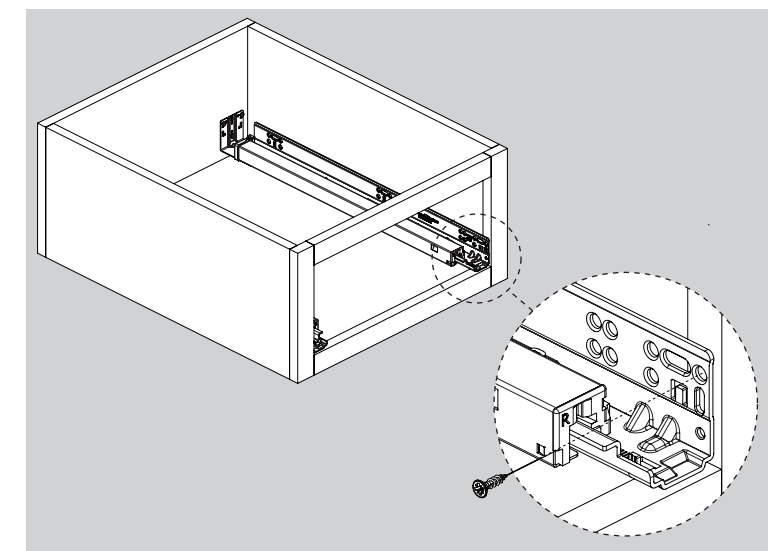
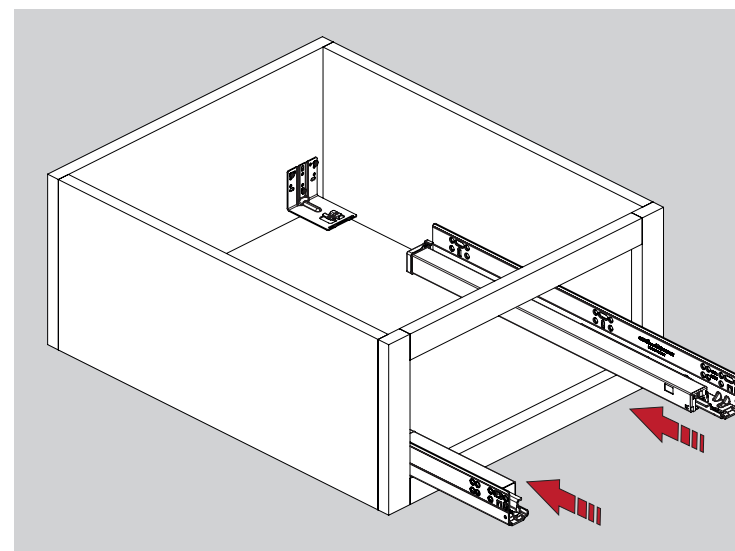
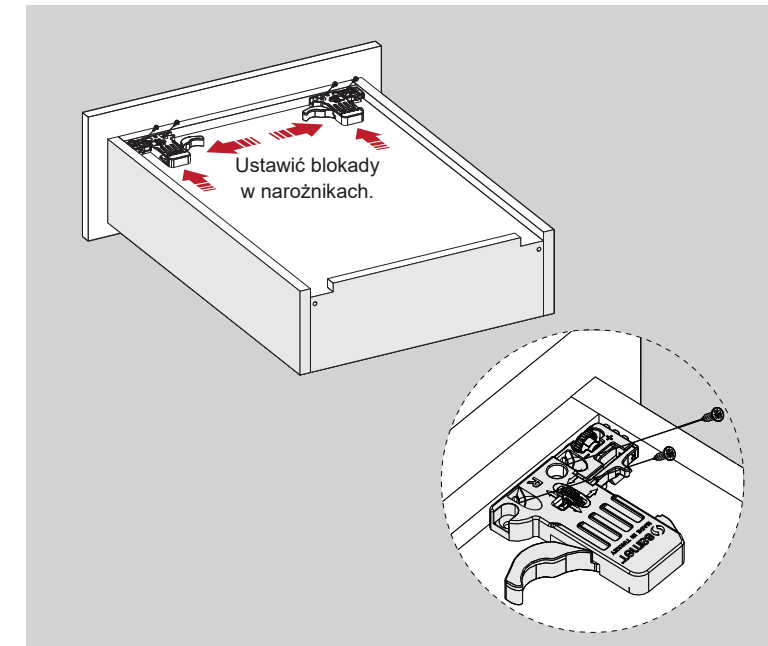
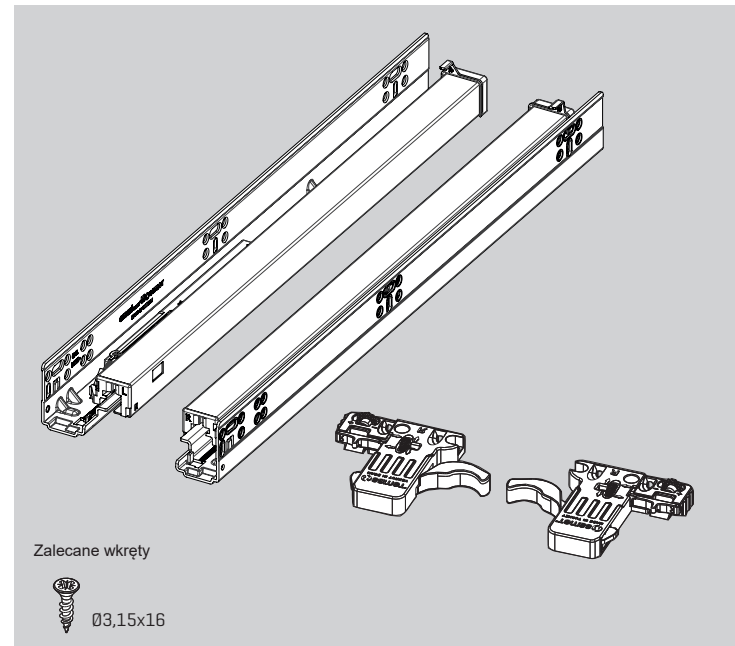

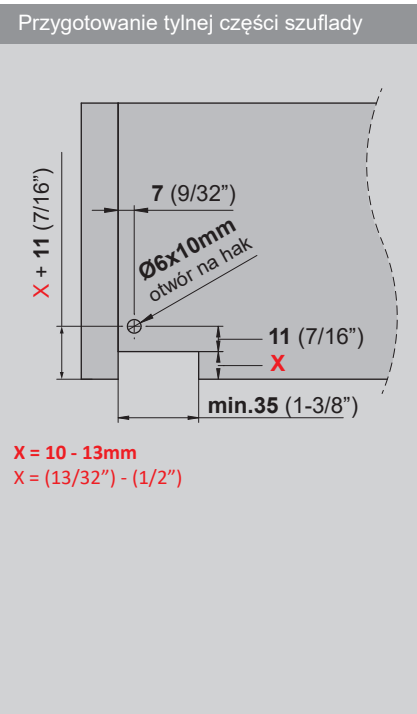
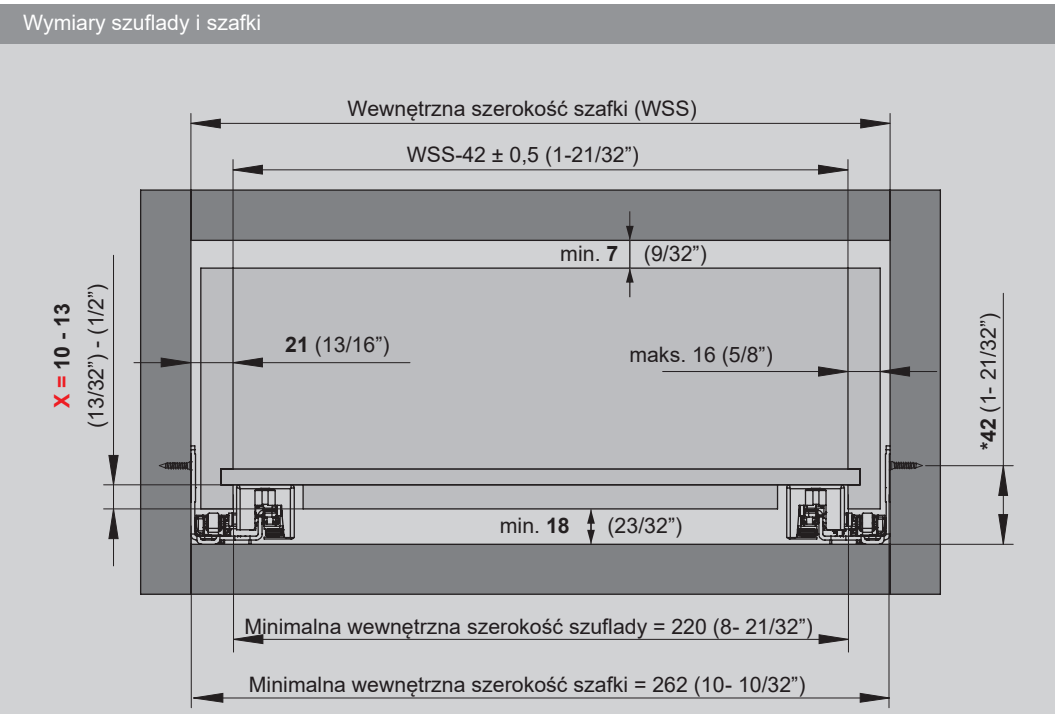

W przypadku szafek bezramowych minimalna odległość środka wkrętu powinna wynosić (*) min. 42 mm (1- 21/32")

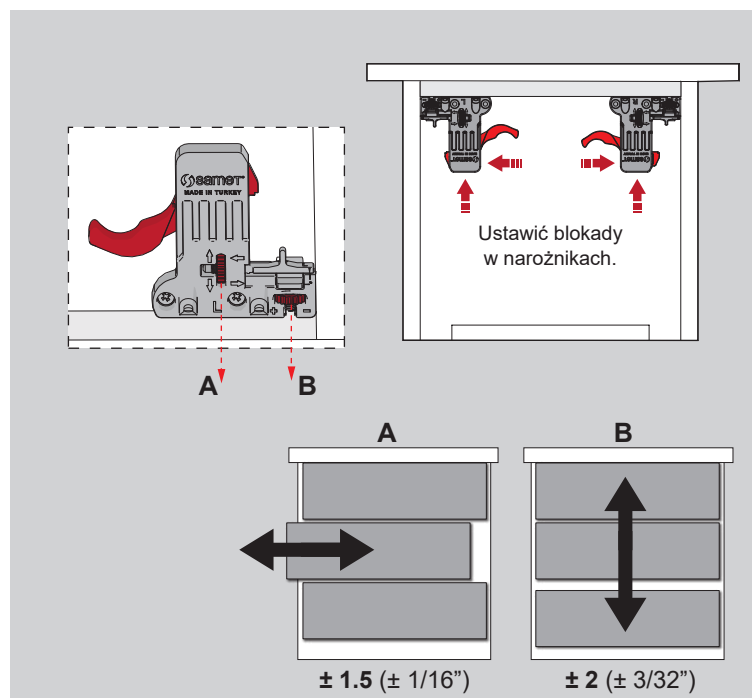
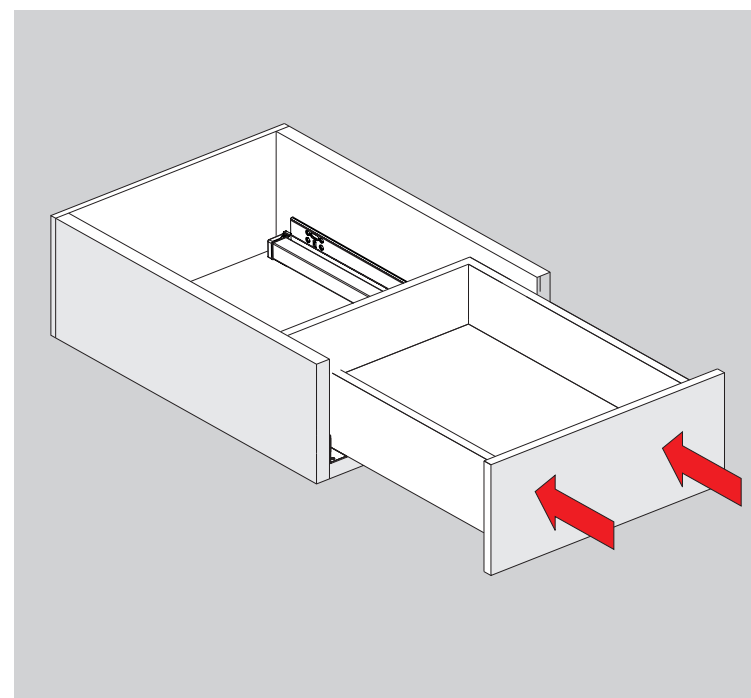
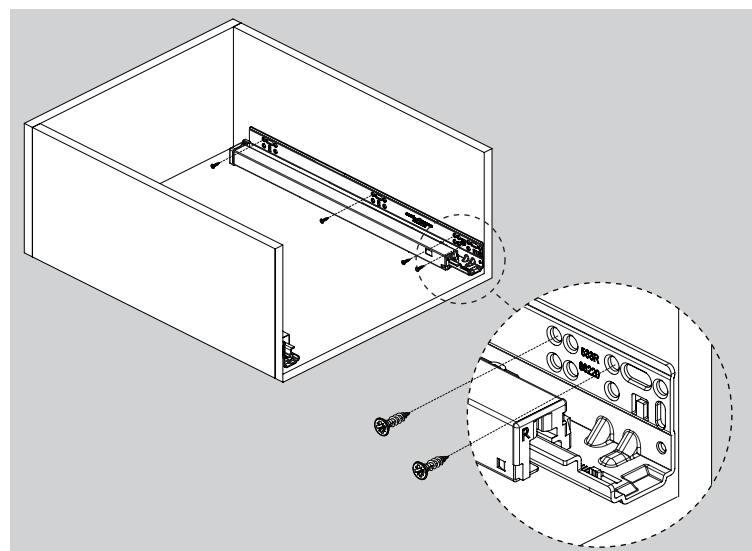
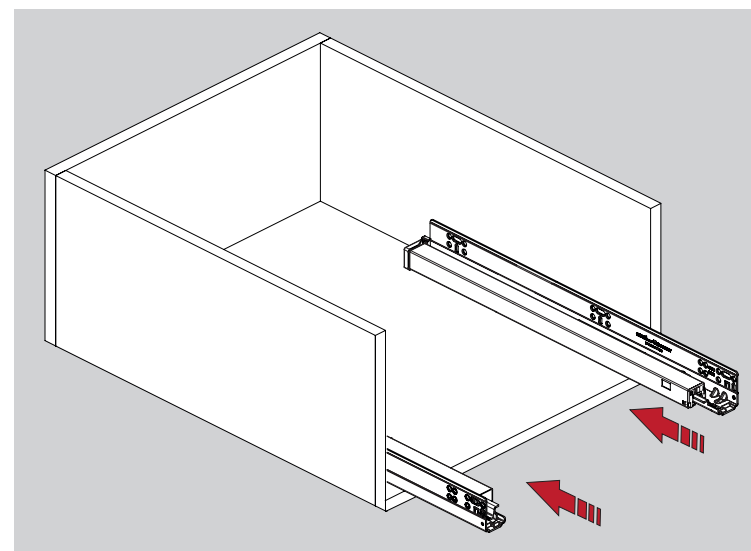
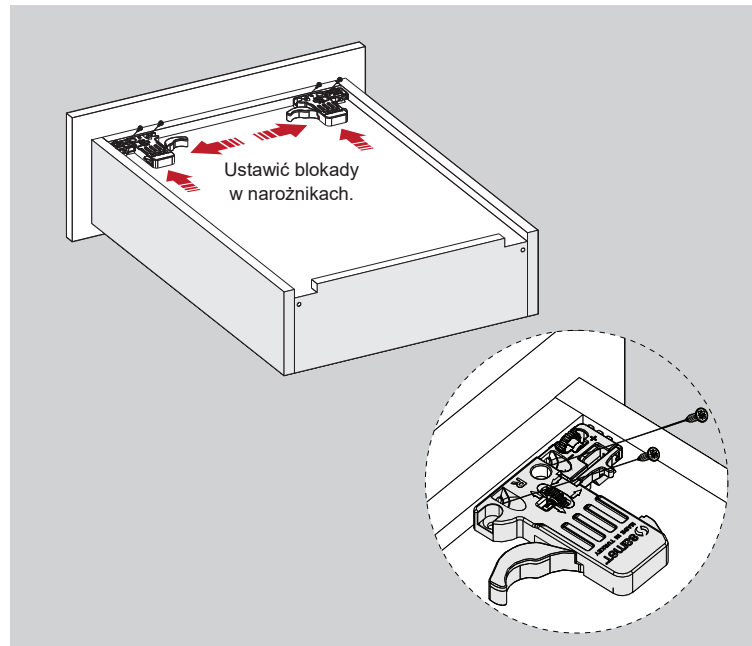
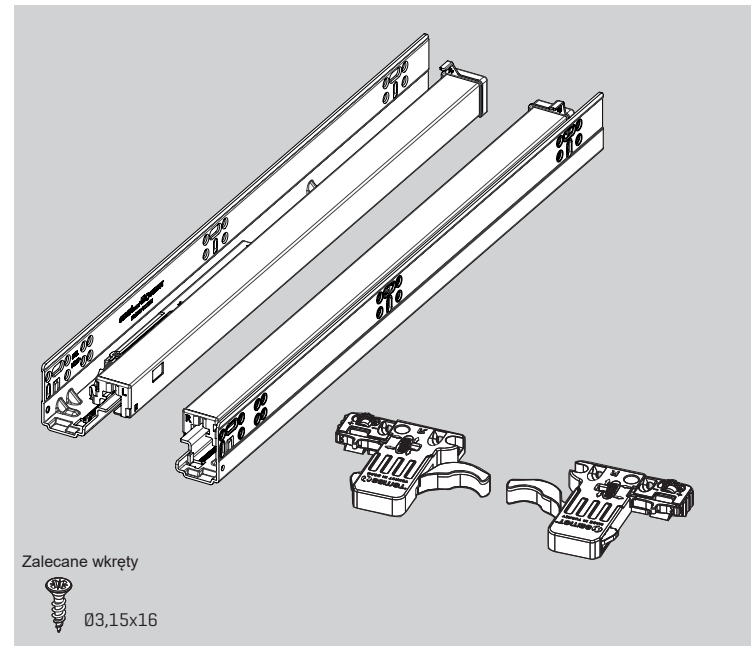
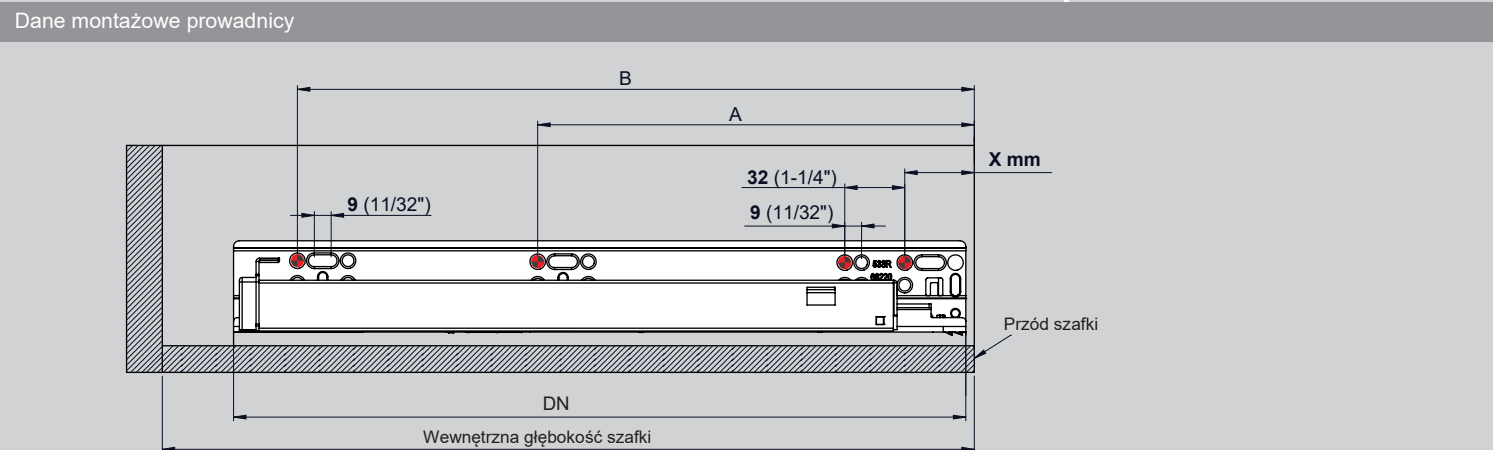

Długość szuflady	Minimalna wewnętrzna głębokość szafki	Długość prowadnicy (DN)	Rozmieszczenie wkrętów dla szafek bezramowych	
			A	B
229 (9")	270 (10-5/8")	261 (10-9/32")	133 (5-7/32")	229 (9")
305 (12")	328 (12-29/32")	319 (12-9/16")	165 (6-1/2")	261 (10-9/32")
381 (15")	404 (15-29/32")	395 (15-9/16")	165 (6-1/2")	357 (14-1/16")
457 (18")	480 (18-29/32")	471 (18-17/32")	261 (10-9/32")	453 (17-27/32")
533 (21")	557 (21-15/16")	548 (21-9/16")	261 (10-9/32")	517 (20-3/8")

Szuflada standardowa

Grubość panelu pod	X (miejsce wiercenia)	
	13 (1/2")	34 (1-11/32")
16 (5/8")	37 (1-15/32")	
19 (3/4")	40 (1-18/32")	

Szuflada wpuszczana

Grubość panelu pod	X (miejsce wiercenia)			
	13 (1/2")	50 (1-31/32")	53 (2-3/32")	56 (2-7/32")
16 (5/8")	53 (2-3/32")	56 (2-7/32")	59 (2-10/32")	59 (2-10/32")
19 (3/4")	56 (2-7/32")	59 (2-10/32")	62 (2-14/32")	62 (2-14/32")
	16 (5/8")	19 (3/4")	22 (7/8")	

Grubość frontu szuflady

Cofnięcie ślizgu dla szuflady standardowej (Zob. tabela szuflad standardowych)

Cofnięcie ślizgu dla szuflady wpuszczanej (Zob. tabela szuflad wpuszczanych)

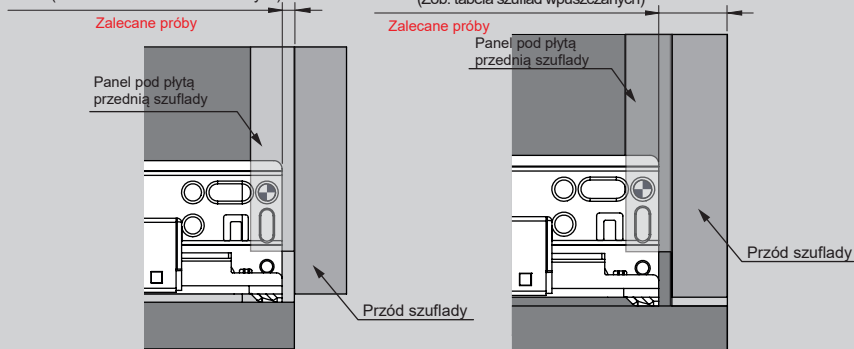

Tabela konwersji milimetrów na cale

1	1.5	2	3	4	5	5.5	6	7	8	9	9.5	10	11	12	13	13.5	14	15	16	17	17.5	18	19	20	20.5	21	22	23	24	24.5	25.4
1/32	1/16	3/32	1/8	5/32	3/16	7/32	1/4	9/32	5/16	11/32	3/8	13/32	7/16	15/32	1/2	17/32	9/16	19/32	5/8	21/32	11/16	23/32	3/4	25/32	13/16	27/32	7/8	29/32	15/16	31/32	1