

Dans une application de montage inférieur sans cadre, la hauteur minimale du centre de la vis doit être de (*) min. 42 mm (1-21/32\"/>

Remarque : Utilisez au moins trois vis par support.

Spécifications de montage des coulisses

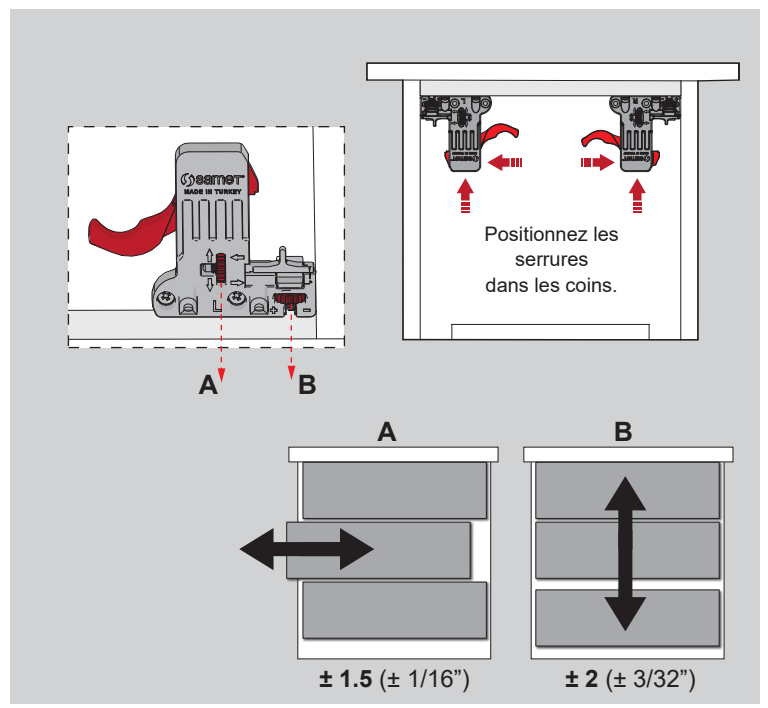
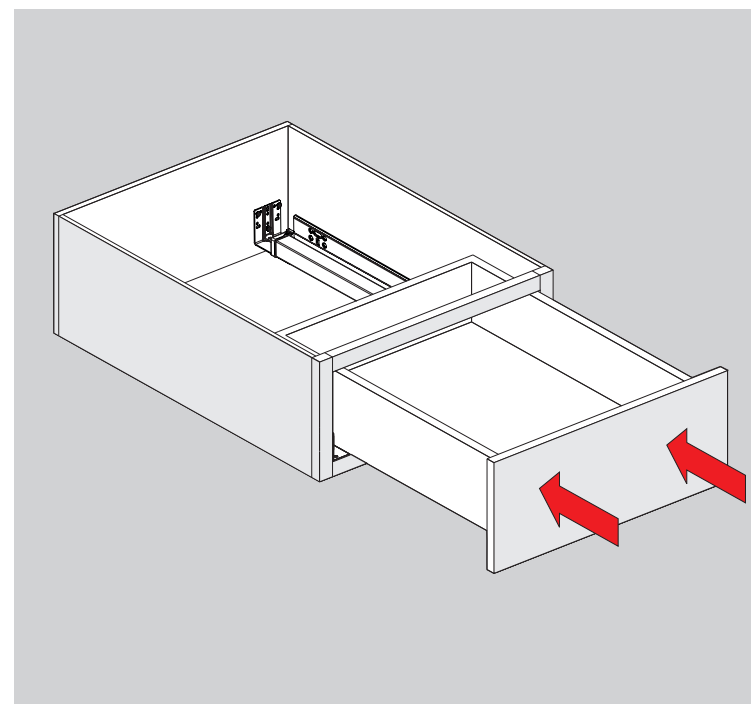
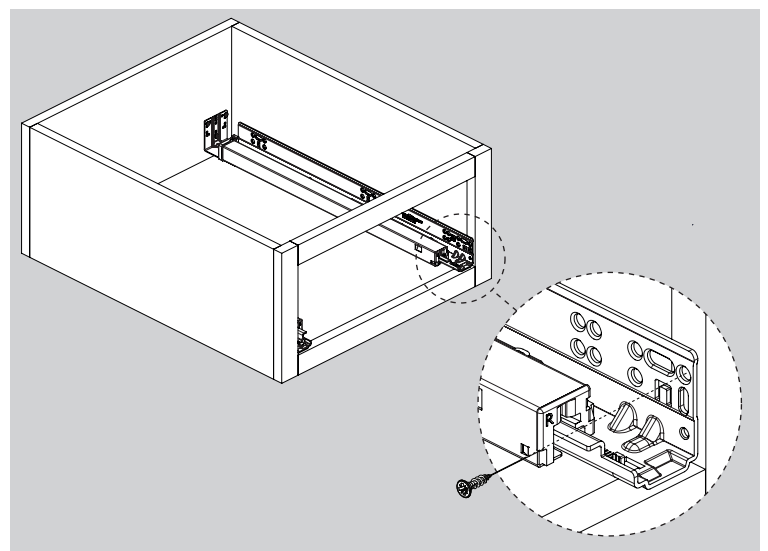
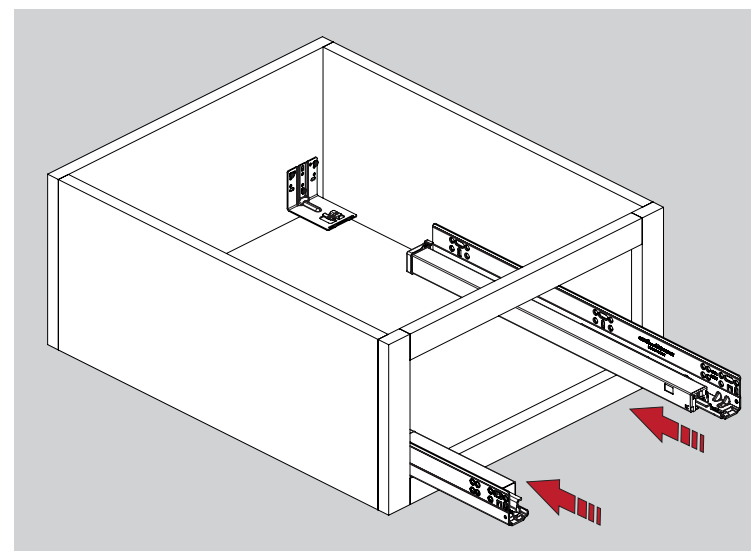
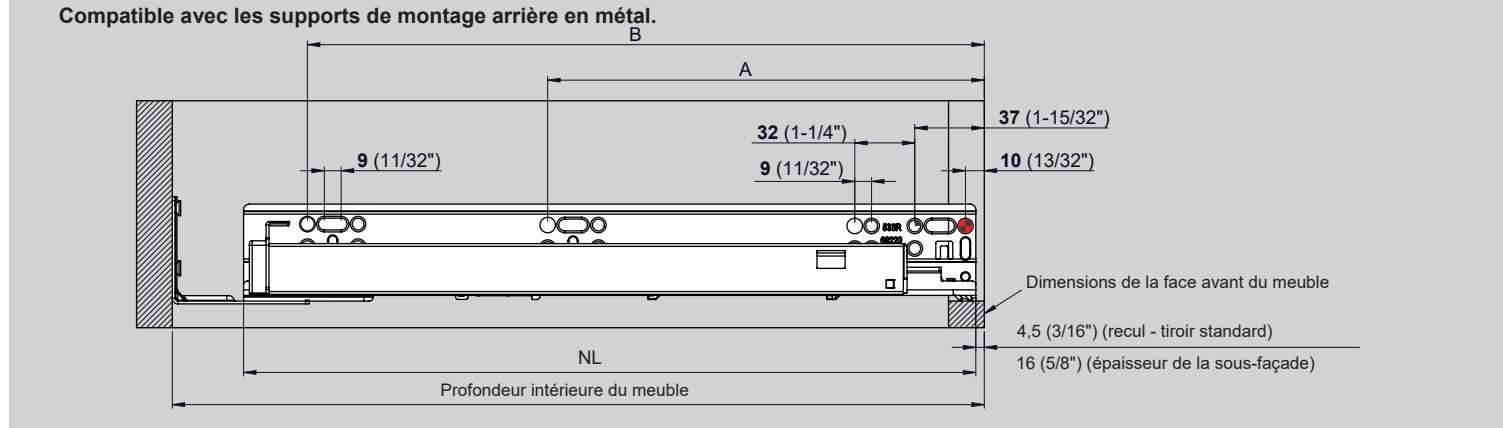

Longueur du tiroir	Profondeur intérieure du meuble avec fixation arrière		Longueur de la coulisse (NL)	Emplacements de vis pour meubles sans cadre	
	Max	Min		A	B
229 (9")	310 (12-7/32")	270 (10-5/8")	261 (10-9/32")	133 (5-7/32")	229 (9")
305 (12")	368 (14-1/2")	328 (12-29/32")	319 (12-9/16")	165 (6-1/2")	261 (10-9/32")
381 (15")	444 (17-1/2")	404 (15-29/32")	395 (15-9/16")	165 (6-1/2")	357 (14-1/16")
457 (18")	520 (20-1/2")	480 (18-29/32")	471 (18-17/32")	261 (10-9/32")	453 (17-27/32")
533 (21")	597 (23-1/2")	557 (21-15/16")	548 (21-9/16")	261 (10-9/32")	517 (20-3/8")

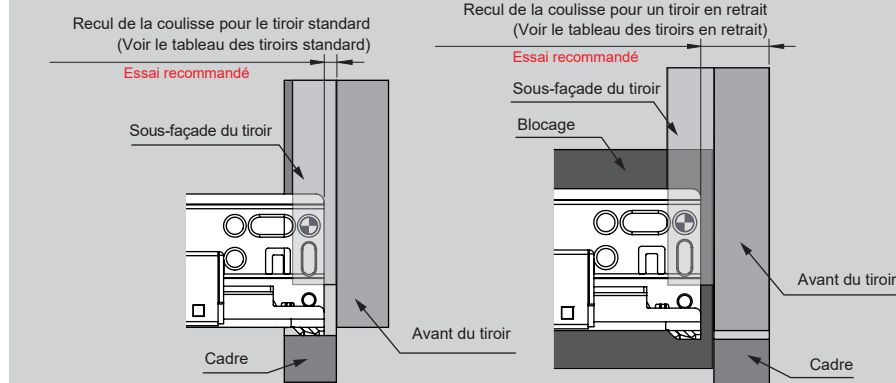

Tiroir standard

Épaisseur de la sous-façade	Recul	
	13 (1/2")	1.5 (1/16")
16 (5/8")	4.5 (3/16")	
19 (3/4")	7.5 (5/16")	

Tiroir en retrait

Épaisseur de la sous-façade	Recul			
	13 (1/2")	17.5 (11/16")	20.5 (13/16")	23.5 (15/16")
16 (5/8")	20.5 (13/16")	23.5 (15/16")	26.5 (1-1/32")	29.5 (1-5/32")
19 (3/4")	23.5 (15/16")	26.5 (1-1/32")	29.5 (1-5/32")	
	16 (5/8")	19 (3/4")	22 (7/8")	

Épaisseur de la façade du tiroir

Tableau de conversion de millimètres en pouces

1	1.5	2	3	4	5	5.5	6	7	8	9	9.5	10	11	12	13	13.5	14	15	16	17	17.5	18	19	20	20.5	21	22	23	24	24.5	25.4
1/32	1/16	3/32	1/8	5/32	3/16	7/32	1/4	9/32	5/16	11/32	3/8	13/32	7/16	15/32	1/2	17/32	9/16	19/32	5/8	21/32	11/16	23/32	3/4	25/32	13/16	27/32	7/8	29/32	15/16	31/32	1

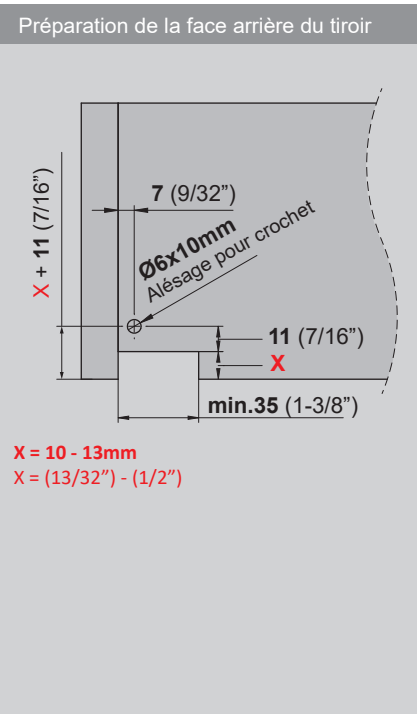
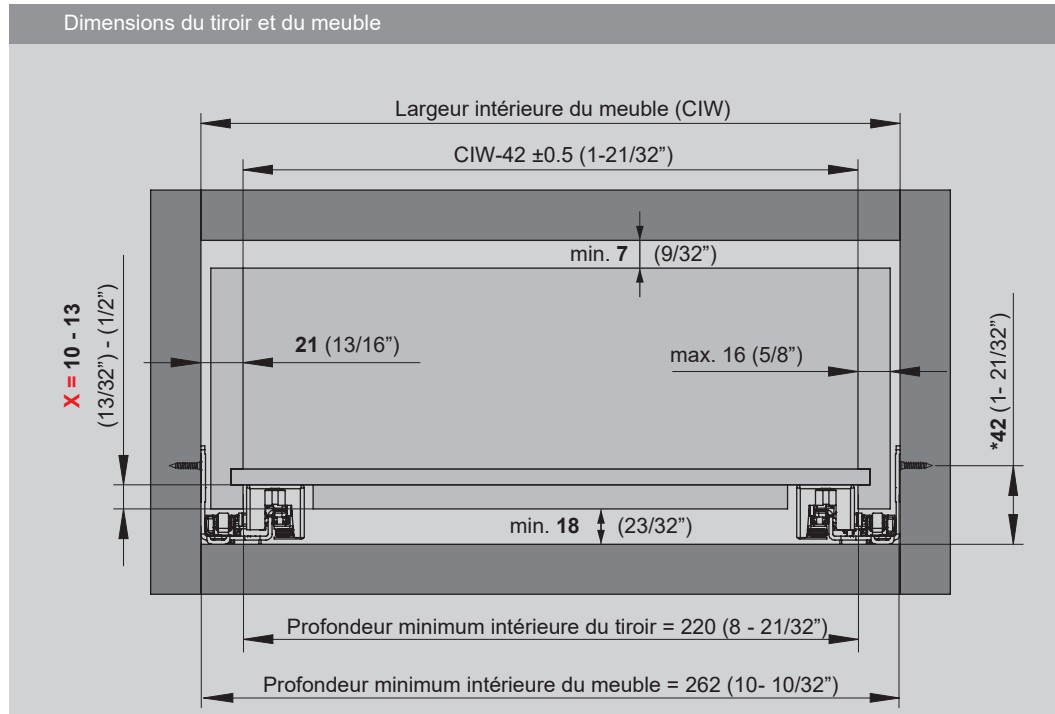

Dans une application de montage inférieur sans cadre, la hauteur minimale du centre de la vis doit être de (*) min. 42 mm (1- 21/32\"/>

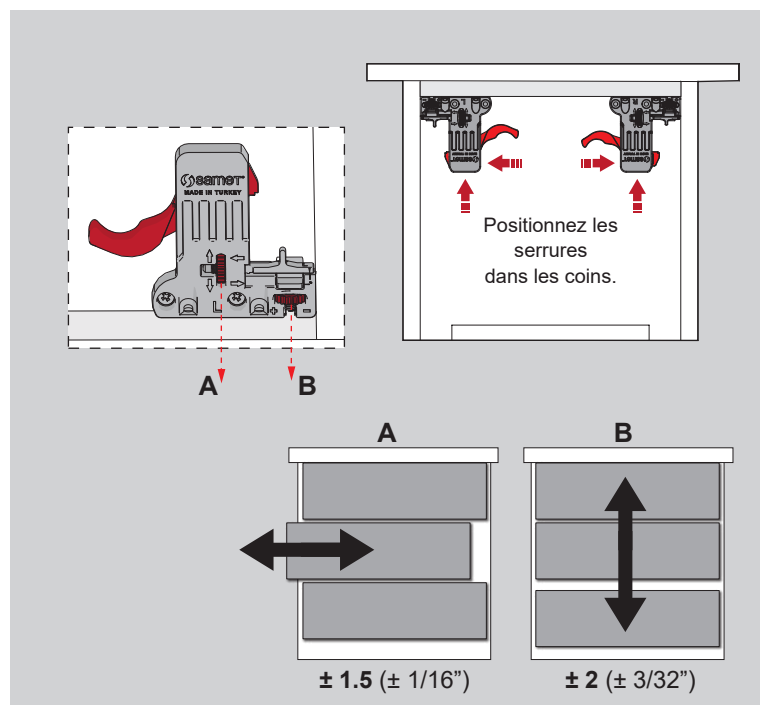
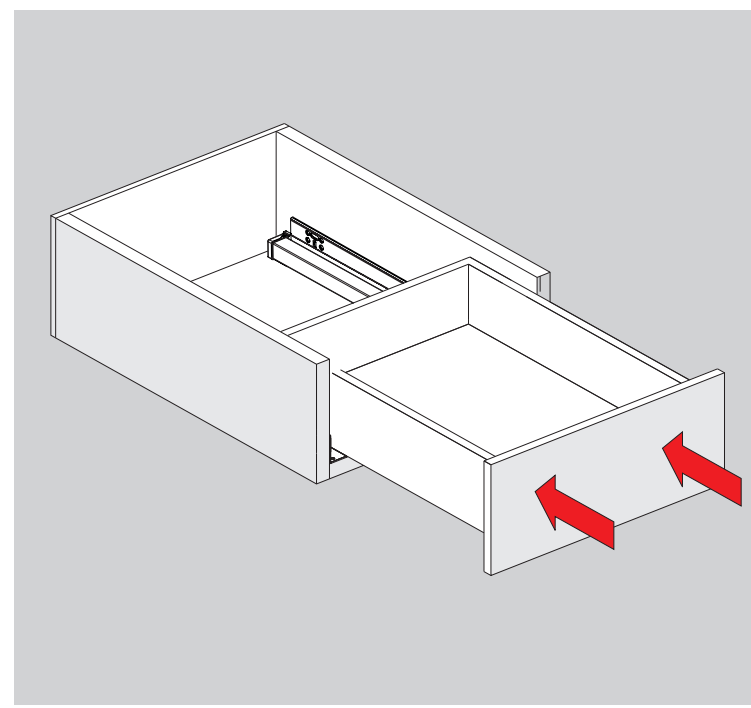
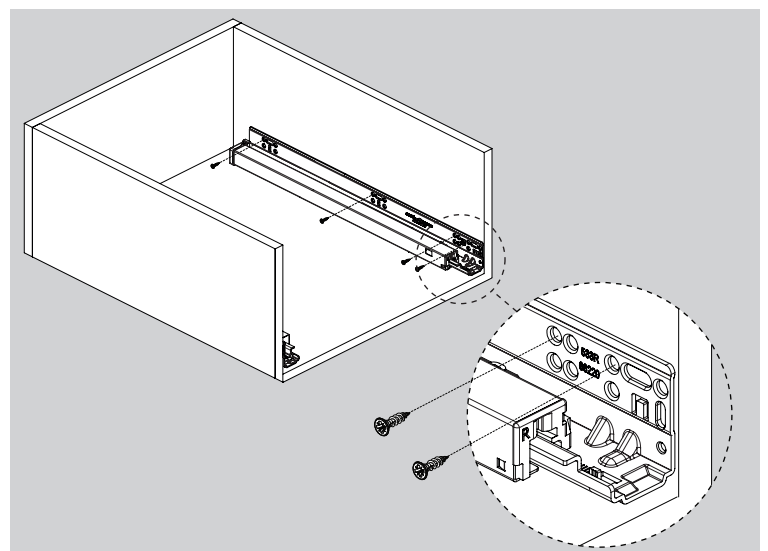
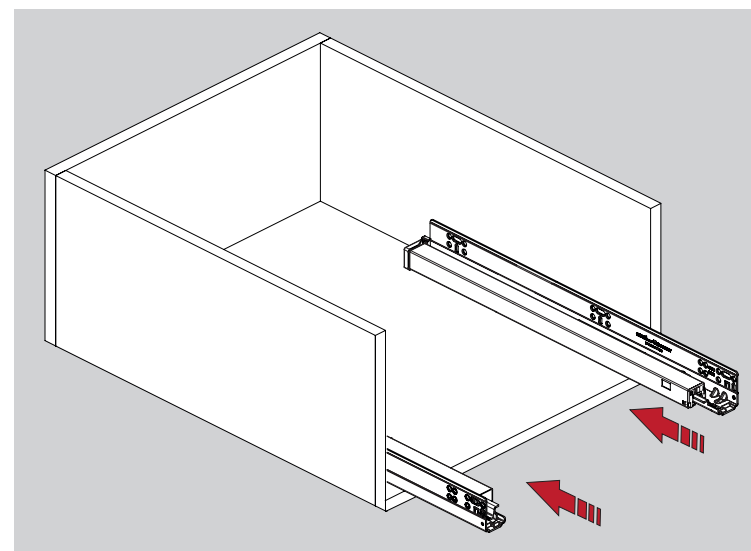
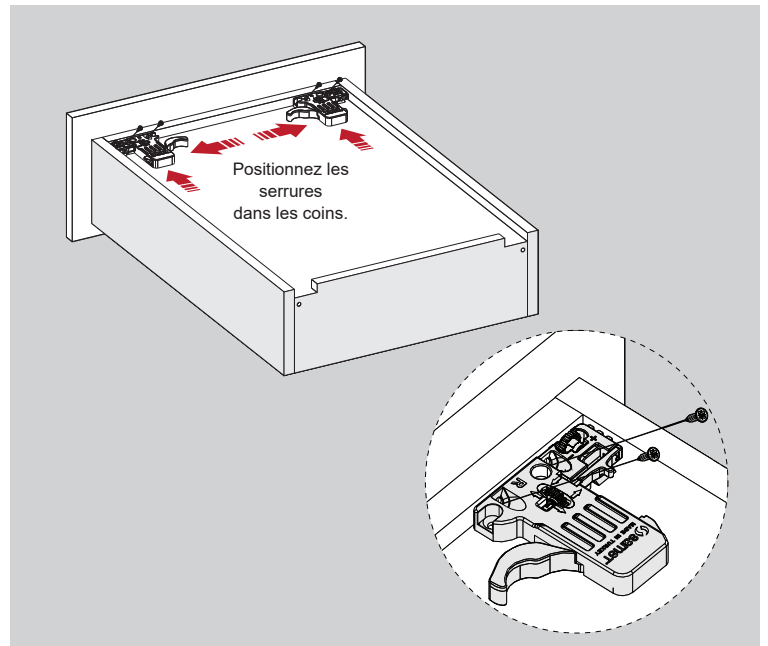
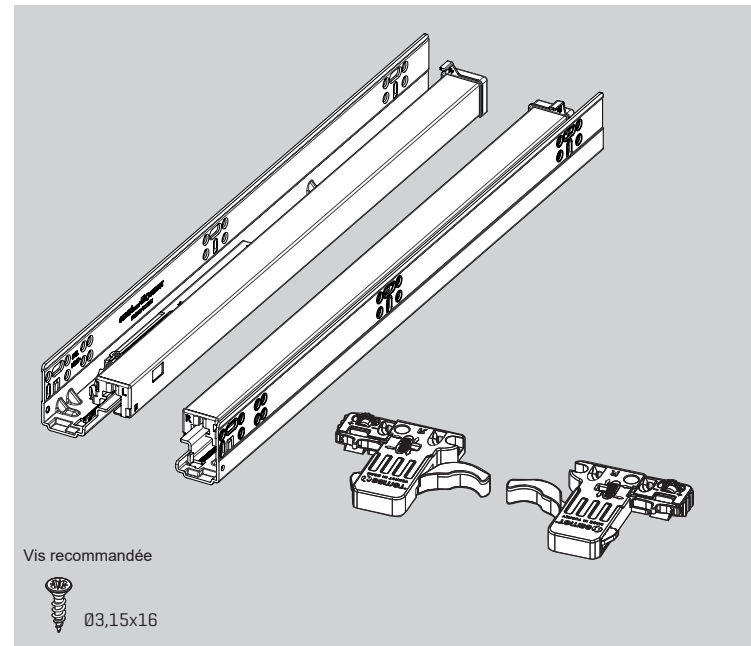
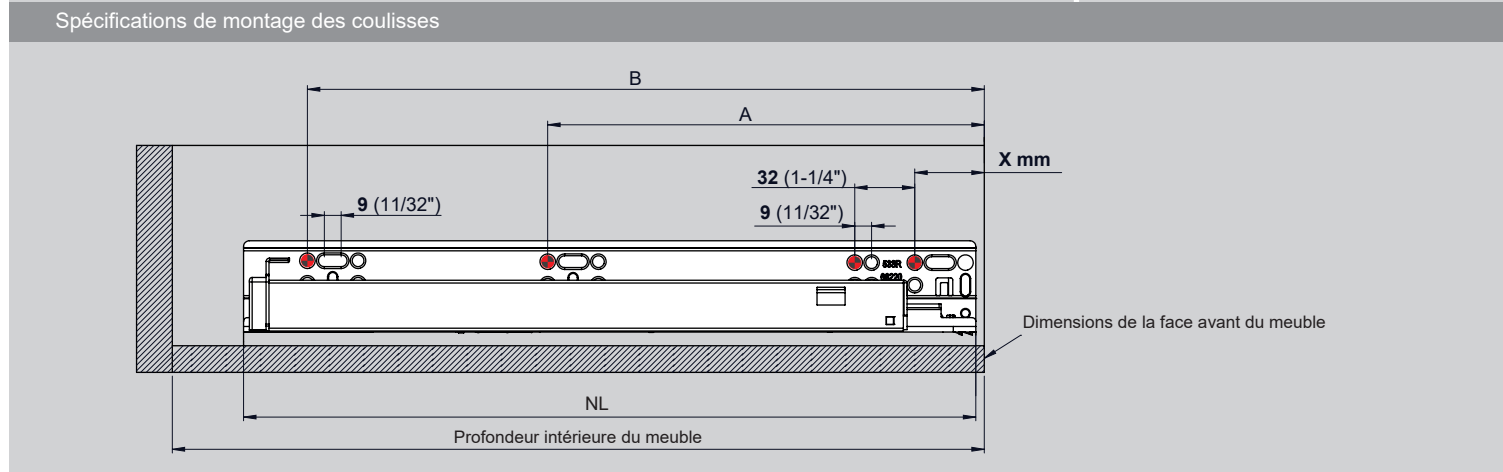

Longueur du tiroir	Profondeur minimum intérieure du meuble	Longueur de la coulisse (NL)	Emplacements de vis pour meubles sans cadre	
			A	B
229 (9")	270 (10-5/8")	261 (10-9/32")	133 (5-7/32")	229 (9")
305 (12")	328 (12-29/32")	319 (12-9/16")	165 (6-1/2")	261 (10-9/32")
381 (15")	404 (15-29/32")	395 (15-9/16")	165 (6-1/2")	357 (14-1/16")
457 (18")	480 (18-29/32")	471 (18-17/32")	261 (10-9/32")	453 (17-27/32")
533 (21")	557 (21-15/16")	548 (21-9/16")	261 (10-9/32")	517 (20-3/8")

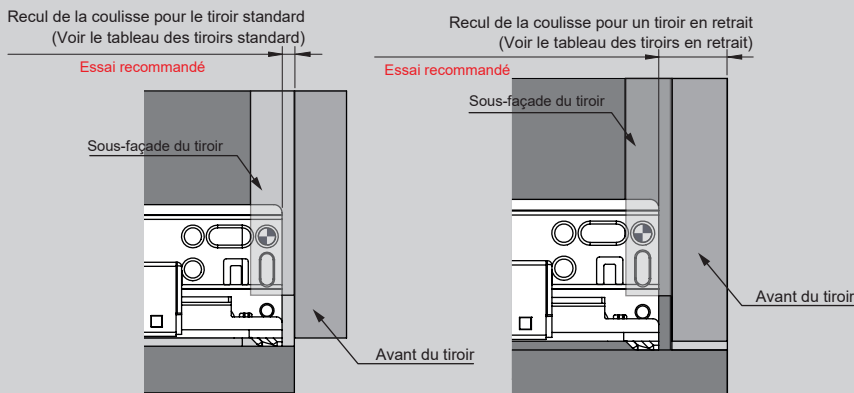

Tiroir standard

Épaisseur de la sous-façade	X (Position de forage)	
	13 (1/2")	34 (1-11/32")
	16 (5/8")	37 (1-15/32")
19 (3/4")	40 (1-18/32")	

Tiroir en retrait

Épaisseur de la sous-façade	X (Position de forage)			
	13 (1/2")	50 (1-31/32")	53 (2-3/32")	56 (2-7/32")
	16 (5/8")	53 (2-3/32")	56 (2-7/32")	59 (2-10/32")
19 (3/4")	56 (2-7/32")	59 (2-10/32")	62 (2-14/32")	
	16 (5/8")	19 (3/4")	22 (7/8")	

Épaisseur de la façade du tiroir

Tableau de conversion de millimètres en pouces

1	1.5	2	3	4	5	5.5	6	7	8	9	9.5	10	11	12	13	13.5	14	15	16	17	17.5	18	19	20	20.5	21	22	23	24	24.5	25.4
1/32	1/16	3/32	1/8	5/32	3/16	7/32	1/4	9/32	5/16	11/32	3/8	13/32	7/16	15/32	1/2	17/32	9/16	19/32	5/8	21/32	11/16	23/32	3/4	25/32	13/16	27/32	7/8	29/32	15/16	31/32	1