

Dimensiones de cajón y armario

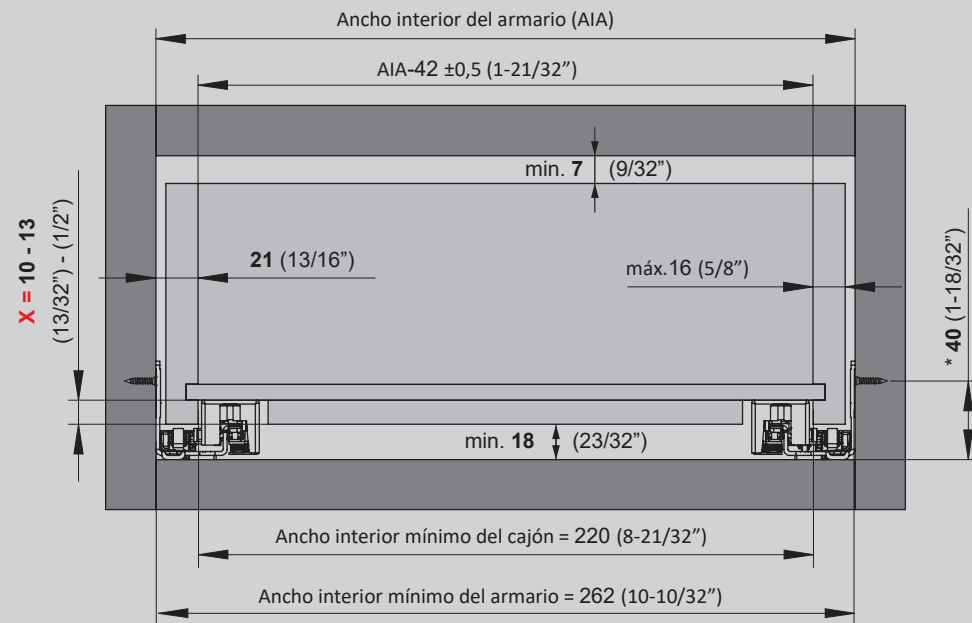

\*Para la aplicación de montaje inferior sin bastidor, la altura mínima del centro del tornillo debe ser (\*) mín. de 42 mm (1-21/32\"/>

Preparación de la parte posterior del cajón

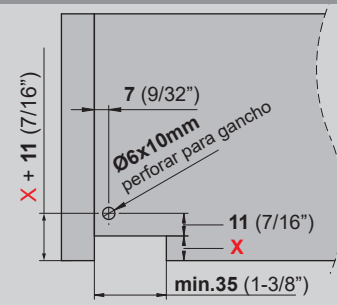

X = 10 - 13mm  
X = (13/32\"/>

Soporte de montaje trasero

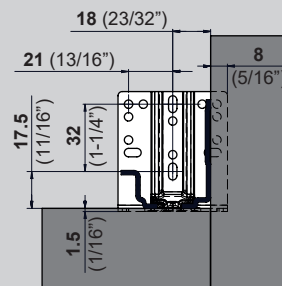

Nota: Utilice un mínimo de tres tornillos por soporte.

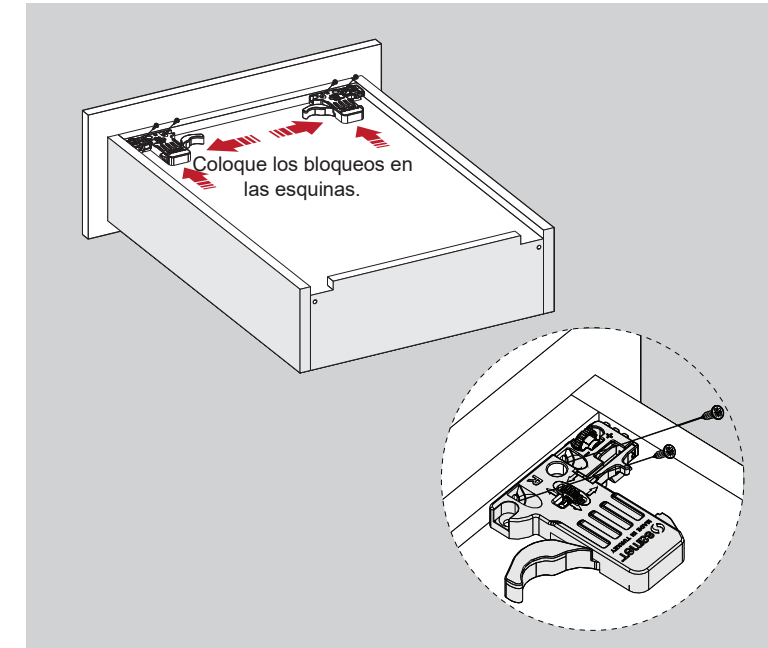
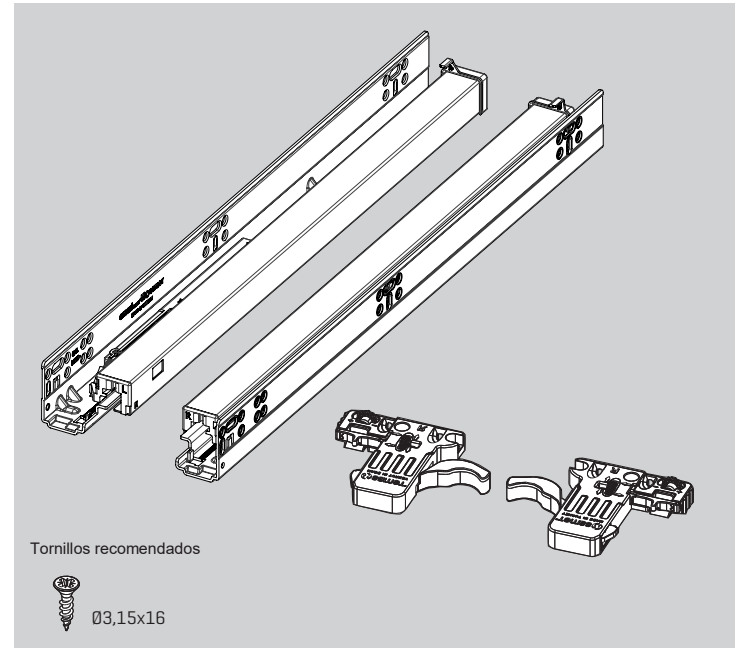

Especificaciones de montaje de corredera

Compatible con soportes de montaje traseros de metal

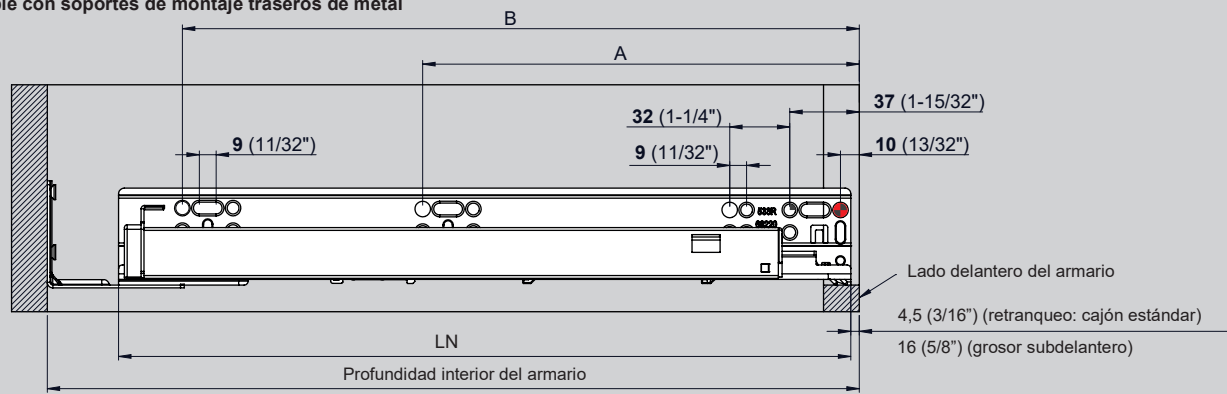

Longitud de cajón	Profundidad interior del armario con fijación trasera		Longitud de corredera (LN)	Ubicaciones de tornillos para armarios sin bastidor	
	Máx.	Mín.		A	B
229 (9")	310 (12-7/32")	270 (10-5/8")	261 (10-9/32")	133 (5-7/32")	229 (9")
305 (12")	368 (14-1/2")	328 (12-29/32")	319 (12-9/16")	165 (6-1/2")	261 (10-9/32")
381 (15")	444 (17-1/2")	404 (15-29/32")	395 (15-9/16")	165 (6-1/2")	357 (14-1/16")
457 (18")	520 (20-1/2")	480 (18-29/32")	471 (18-17/32")	261 (10-9/32")	453 (17-27/32")
533 (21")	597 (23-1/2")	557 (21-15/16")	548 (21-9/16")	261 (10-9/32")	517 (20-3/8")

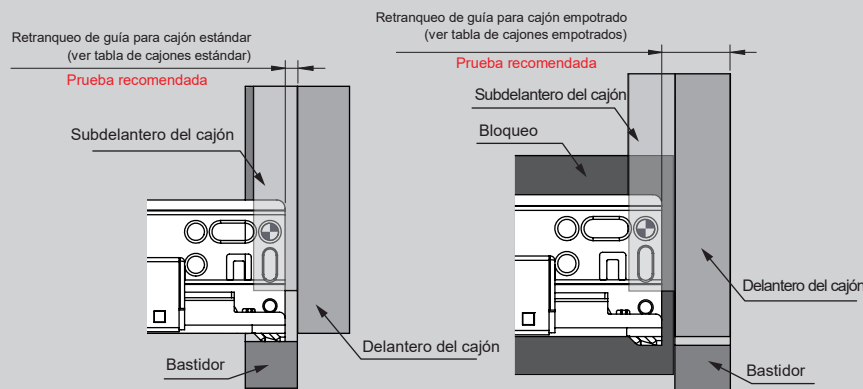

Cajón estándar		
Grosor subdelantero	Retranqueo	Retranqueo
13 (1/2")	1.5 (1/16")	4.5 (3/16")
16 (5/8")	4.5 (3/16")	7.5 (5/16")
19 (3/4")	7.5 (5/16")	

Cajón empotrado				
Grosor subdelantero	Retranqueo			
	13 (1/2")	17.5 (11/16")	20.5 (13/16")	23.5 (15/16")
16 (5/8")	20.5 (13/16")	23.5 (15/16")	26.5 (1-1/32")	29.5 (1-5/32")
19 (3/4")	23.5 (15/16")	26.5 (1-1/32")	29.5 (1-5/32")	
	16 (5/8")	19 (3/4")	22 (7/8")	

Grosor de delantero del cajón



Tabla de conversión de milímetro a pulgada

1	1.5	2	3	4	5	5.5	6	7	8	9	9.5	10	11	12	13	13.5	14	15	16	17	17.5	18	19	20	20.5	21	22	23	24	24.5	25.4
1/32	1/16	3/32	1/8	5/32	3/16	7/32	1/4	9/32	5/16	11/32	3/8	13/32	7/16	15/32	1/2	17/32	9/16	19/32	5/8	21/32	11/16	23/32	3/4	25/32	13/16	27/32	7/8	29/32	15/16	31/32	1

Dimensiones de cajón y armario

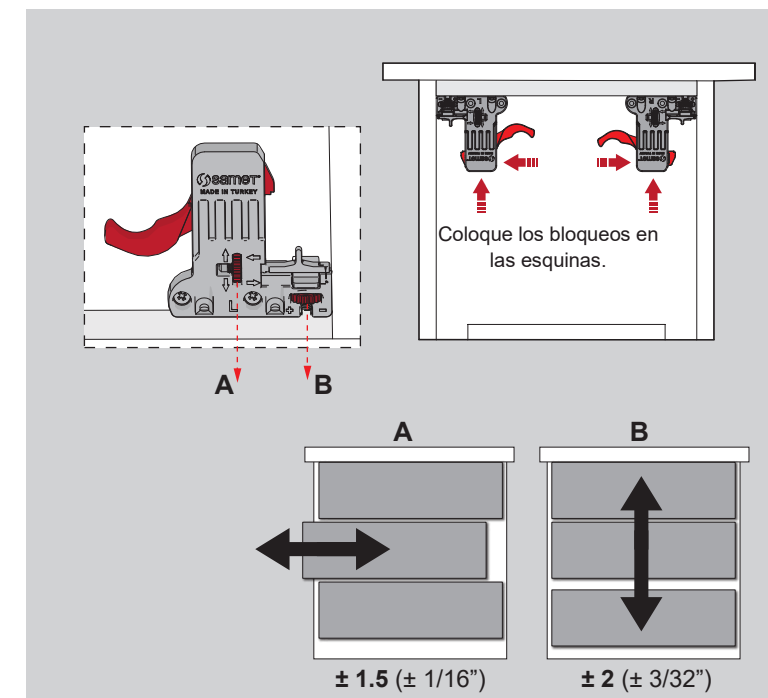
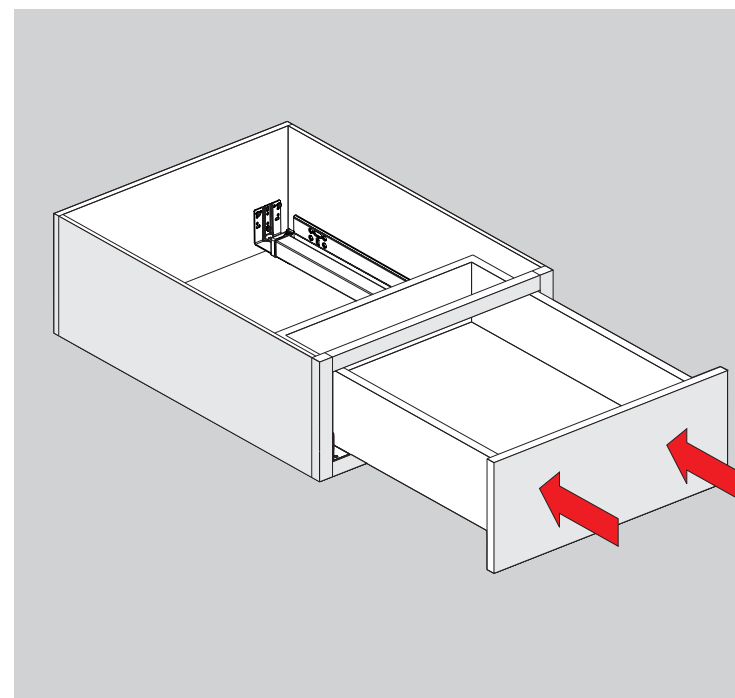
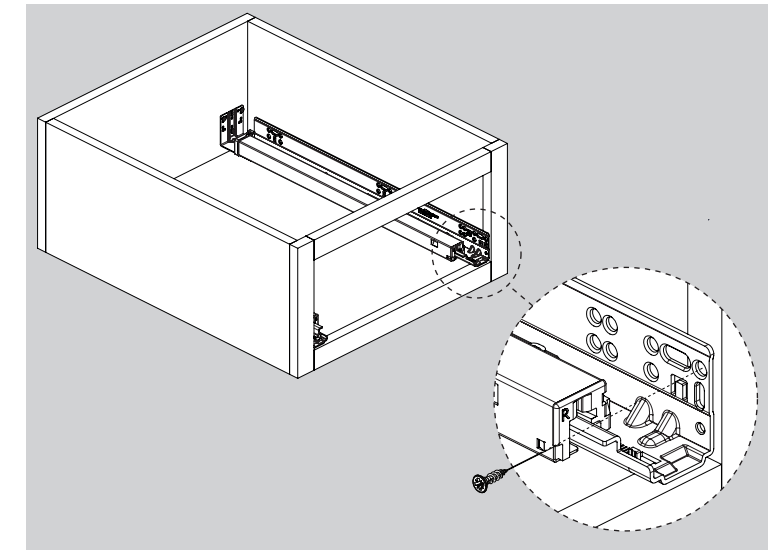
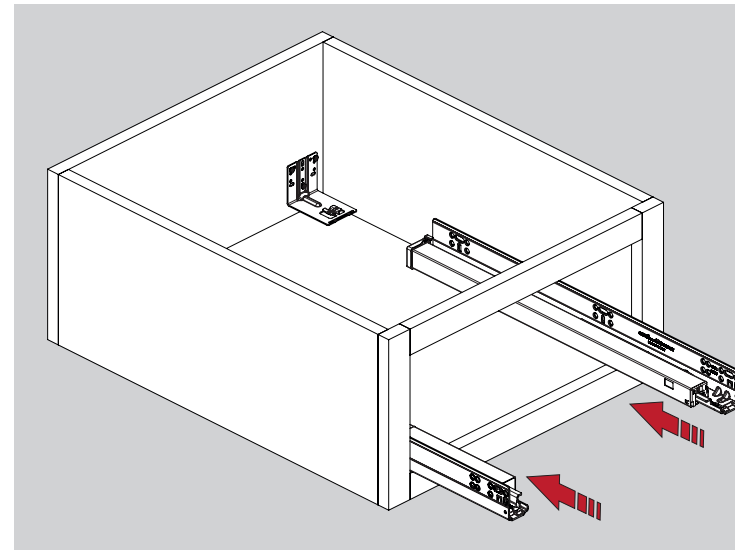
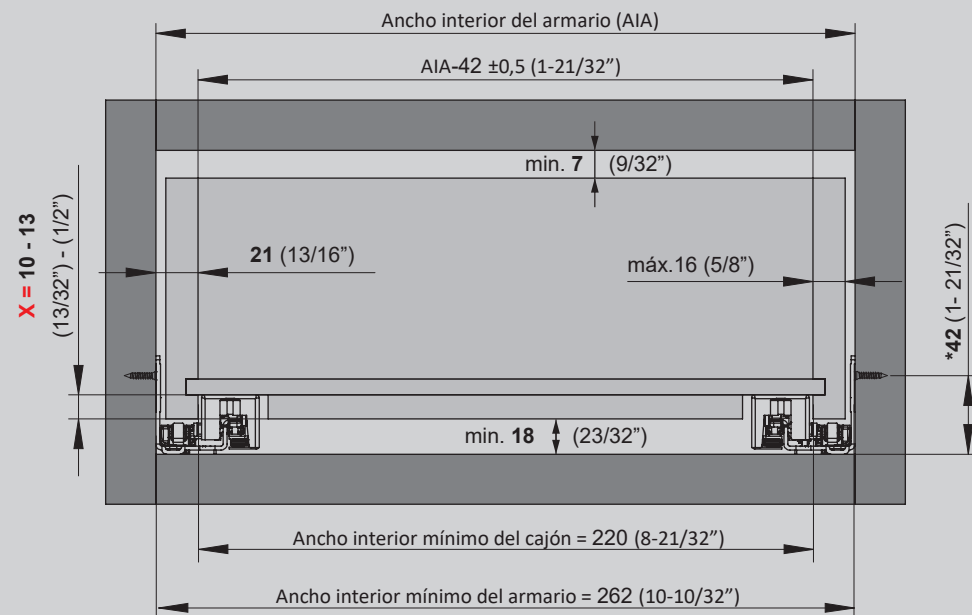

\*Para la aplicación de montaje inferior sin bastidor, la altura mínima del centro del tornillo debe ser (\*) mín. de 42 mm (1-21/32").

Preparación de la parte posterior del cajón

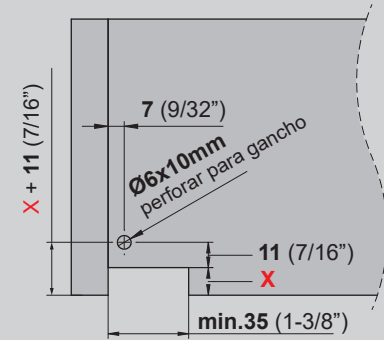

X = 10 - 13mm  
X = (13/32") - (1/2")

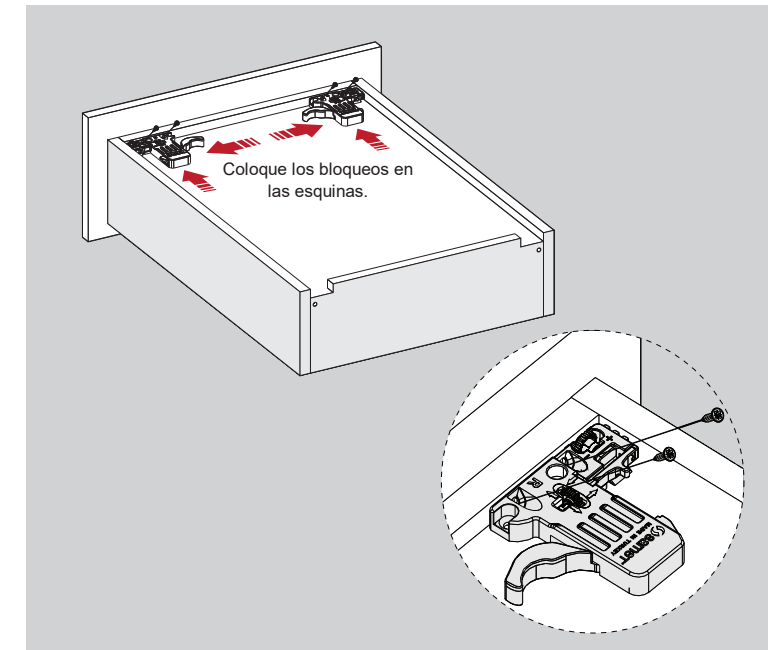
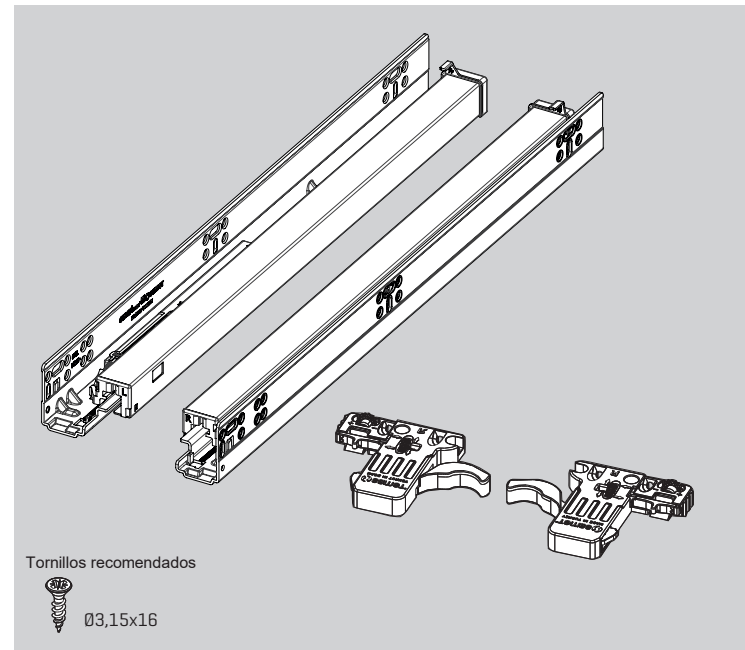

Especificaciones de montaje de corredera

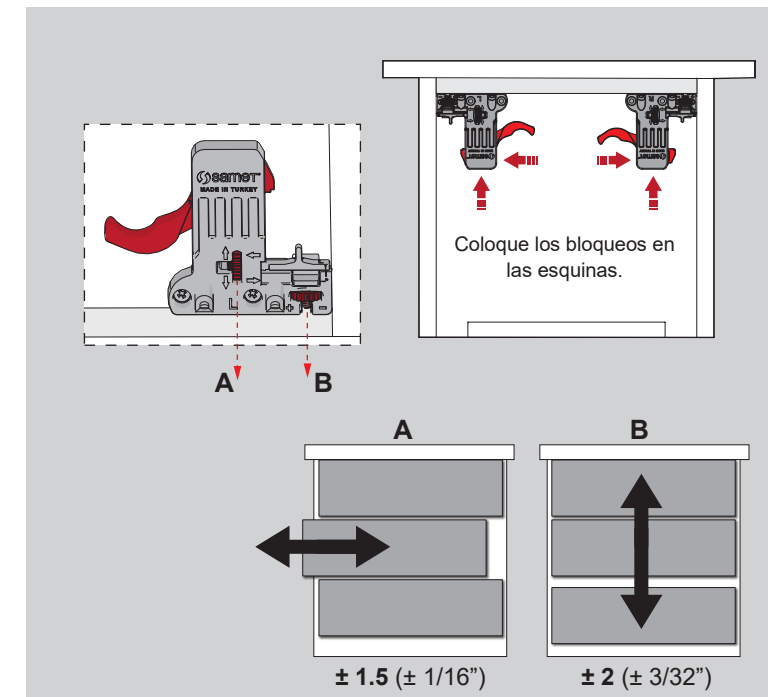
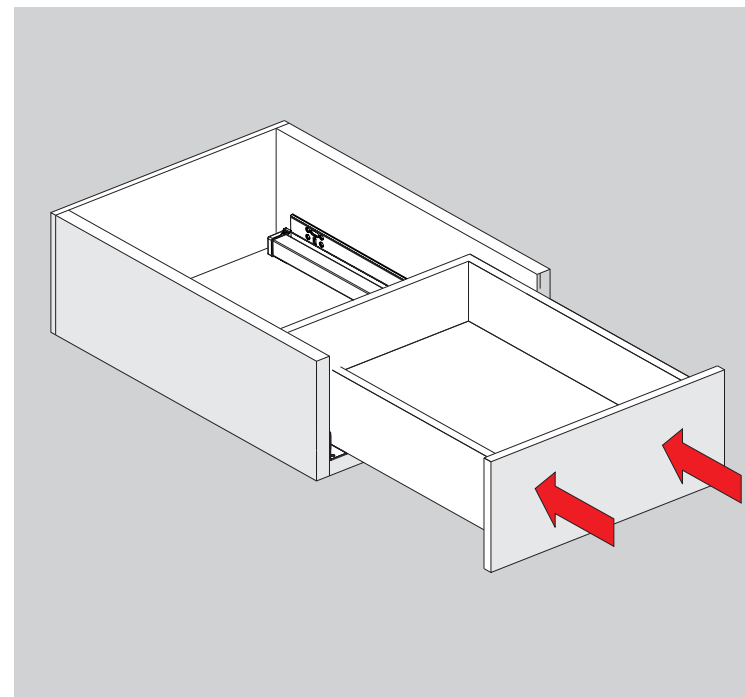
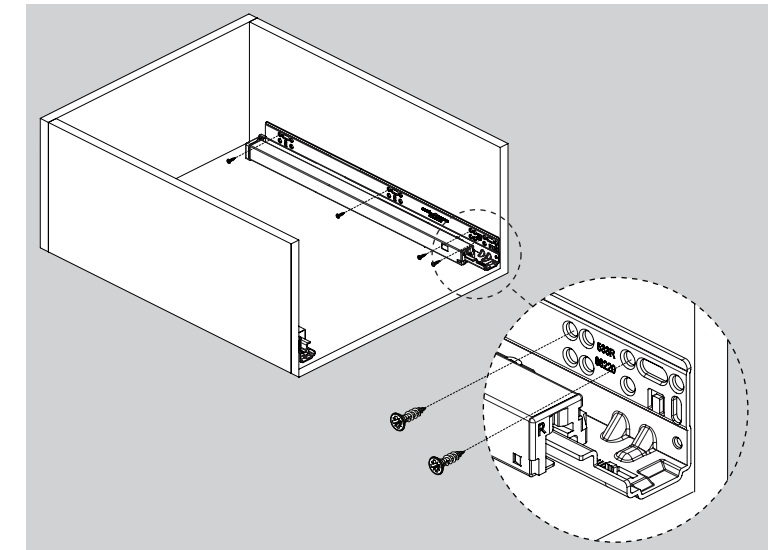
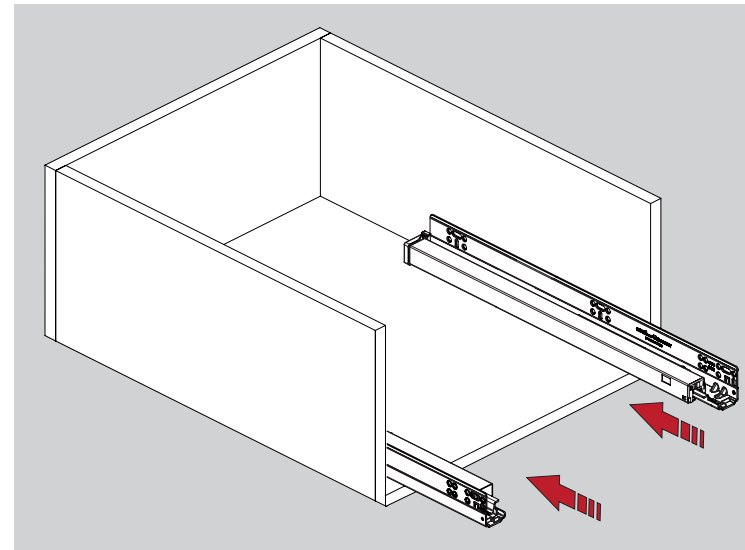
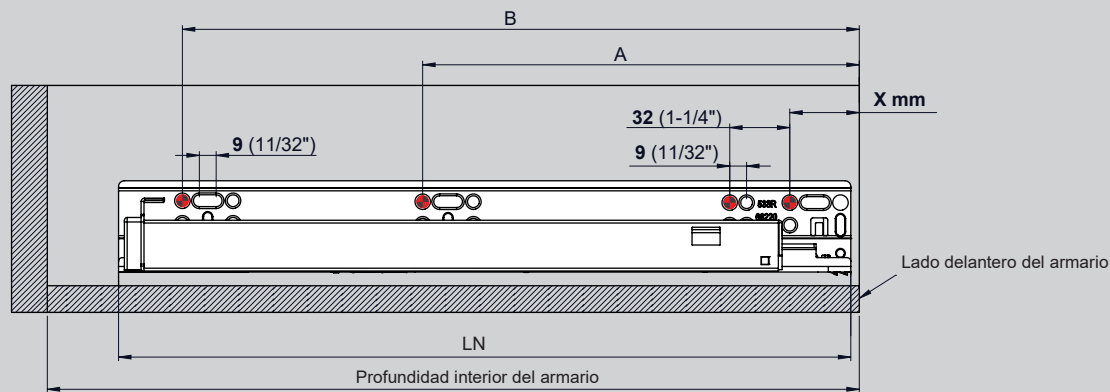

Longitud de cajón	Profundidad mínima interior del armario	Longitud de corredera (LN)	Ubicaciones de tornillos para armarios sin bastidor	
			A	B
229 (9")	270 (10-5/8")	261 (10-9/32")	133 (5-7/32")	229 (9")
305 (12")	328 (12-29/32")	319 (12-9/16")	165 (6-1/2")	261 (10-9/32")
381 (15")	404 (15-29/32")	395 (15-9/16")	165 (6-1/2")	357 (14-1/16")
457 (18")	480 (18-29/32")	471 (18-17/32")	261 (10-9/32")	453 (17-27/32")
533 (21")	557 (21-15/16")	548 (21-9/16")	261 (10-9/32")	517 (20-3/8")

Retranqueo de guía para cajón estándar (ver tabla de cajones estándar)

Retranqueo de guía para cajón empotrado (ver tabla de cajones empotrados)

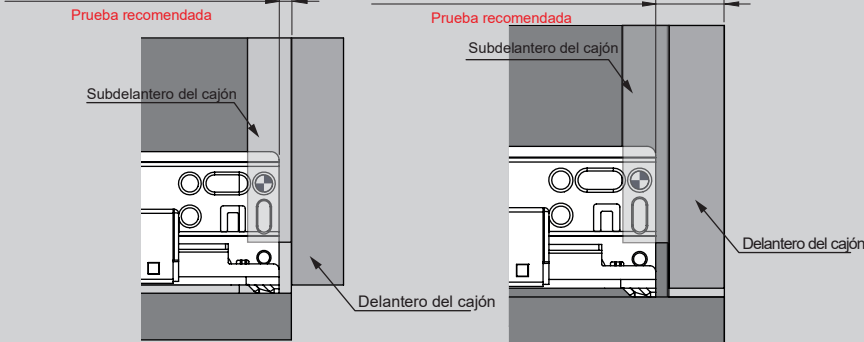

Cajón estándar		X (posición para taladrar)	
Grosor	13 (1/2")	34 (1-11/32")	
subdelantero	16 (5/8")	37 (1-15/32")	
	19 (3/4")	40 (1-18/32")	

Cajón empotrado		X (posición para taladrar)		
Grosor subdelanter	13 (1/2")	50 (1-31/32")	53 (2-3/32")	56 (2-7/32")
	16 (5/8")	53 (2-3/32")	56 (2-7/32")	59 (2-10/32")
	19 (3/4")	56 (2-7/32")	59 (2-10/32")	62 (2-14/32")
		16 (5/8")	19 (3/4")	22 (7/8")
Grosor de delantero del cajón				

Tabla de conversión de milímetro a pulgada

1	1.5	2	3	4	5	5.5	6	7	8	9	9.5	10	11	12	13	13.5	14	15	16	17	17.5	18	19	20	20.5	21	22	23	24	24.5	25.4
1/32	1/16	3/32	1/8	5/32	3/16	7/32	1/4	9/32	5/16	11/32	3/8	13/32	7/16	15/32	1/2	17/32	9/16	19/32	5/8	21/32	11/16	23/32	3/4	25/32	13/16	27/32	7/8	29/32	15/16	31/32	1