

Dimensions techniques et montage

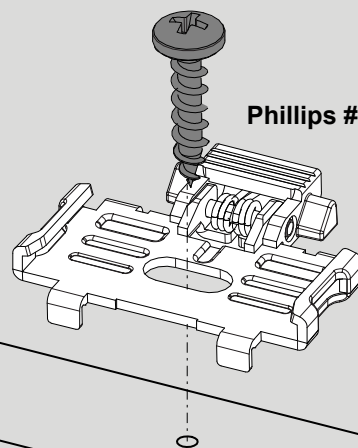

Phillips #8 x 3/4" x #2

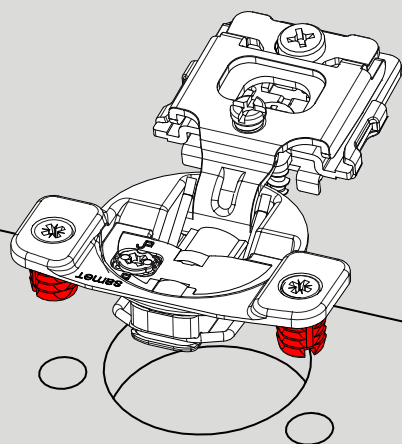
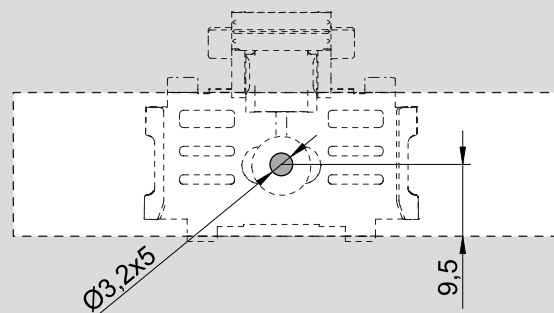
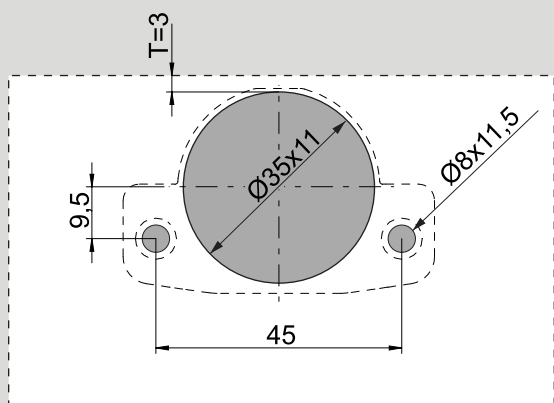
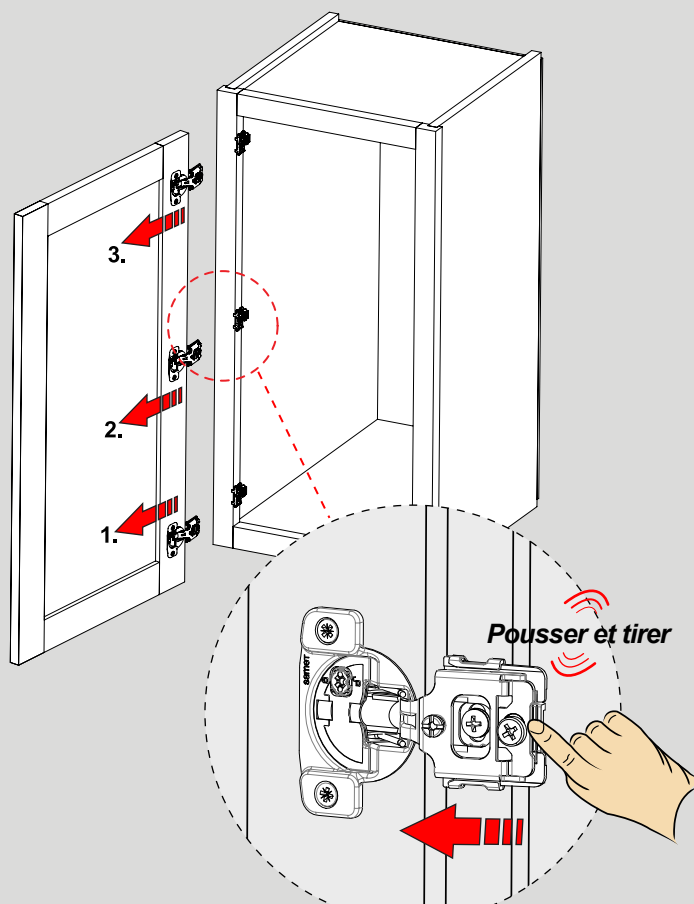
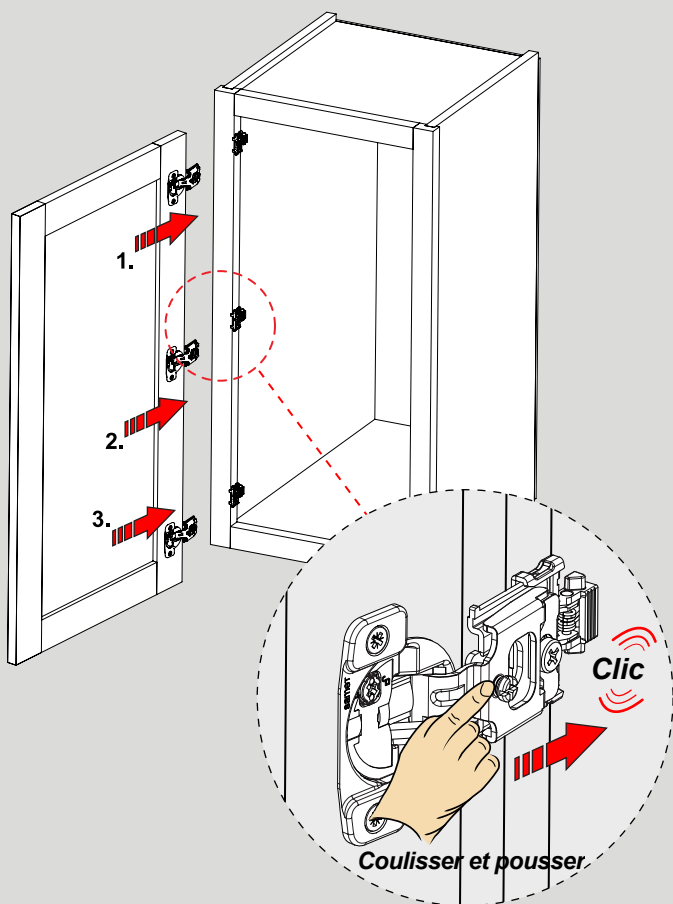

Réglages

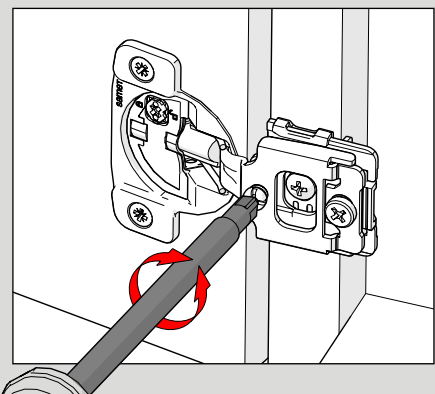
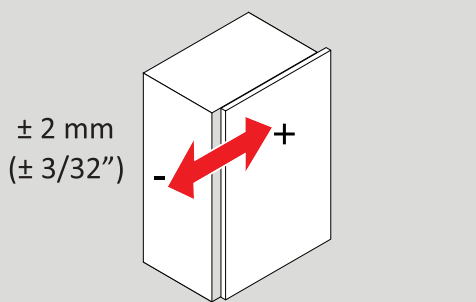

Réglage latéral

Tournez la vis dans le sens des aigu d'une montre ou dans le sens inver

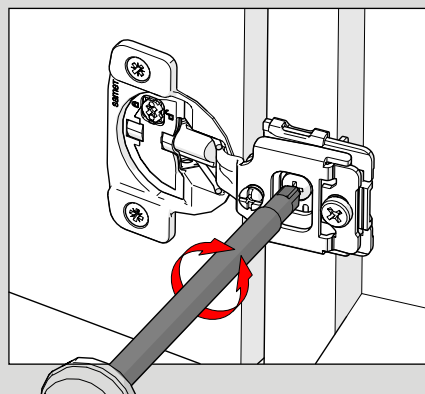
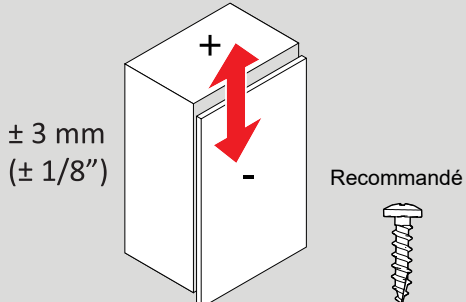

Phillips #8 x 3/4" x #2

Réglage de la hauteur

Desserrez la vis, alignez la porte, serr vis

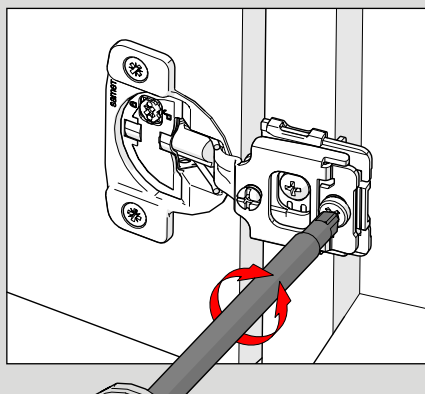
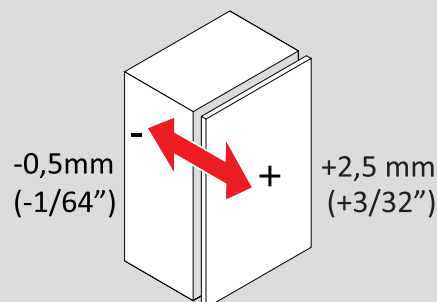

Réglage de la profondeur

Réalisable grâce à un réglage r came

1 Étape

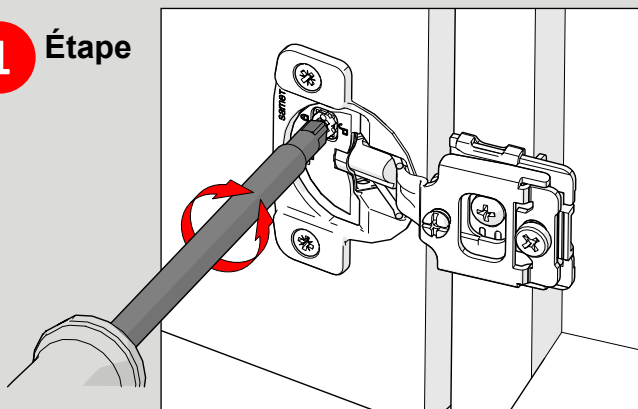

ON

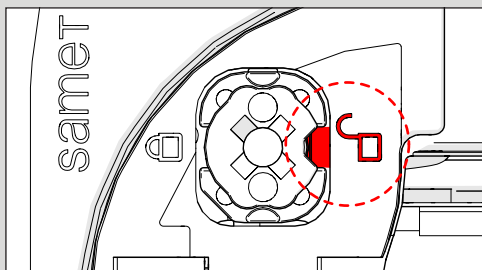

OFF

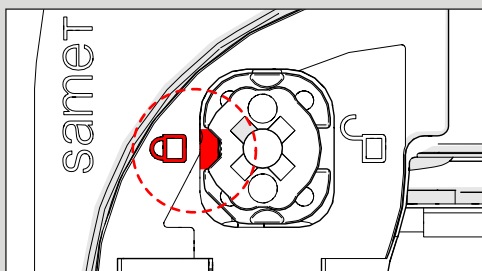

2 Étape

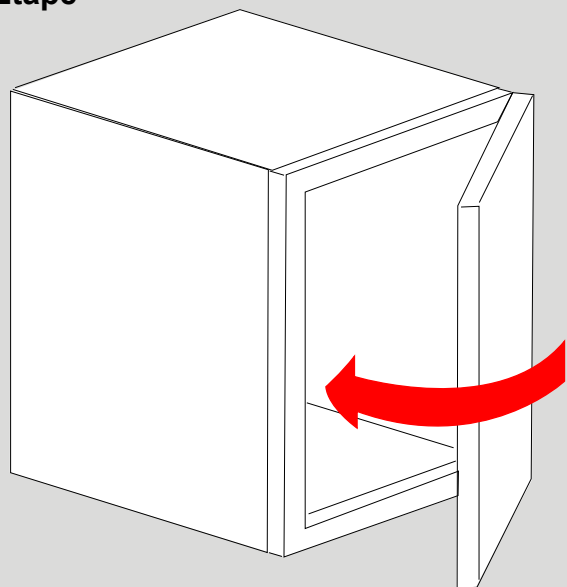

Désactivation de la fermeture amortie de la porte
La porte doit être fermée une fois pour permettre la désactivation complète