

# STAR

The Classical Hinge

**Star Hinge**, the classical product of SAMET, provides different solutions with its large product range, meets with customers for many years.



## Perfect Design

**Star Hinge**, which provides different solutions to meet users' needs, steps forward with its simple design, durability and long life structure. Star Hinge provides wide range adjustment option.



## Easy Installation

SAMET developed **Star Hinge** in a way that ensures easy assembly-disassembly of hinge onto mounting plate feature just by using a screwdriver. It simplifies installation process during production.

## High Quality

**Star Hinge Series** were designed with the advanced technology of SAMET R&D Center and produced by using fully - automated robotic production systems.



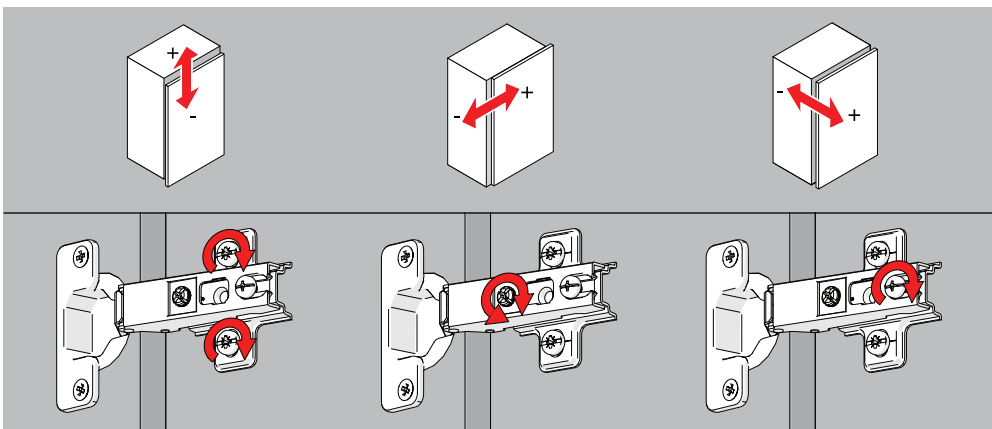
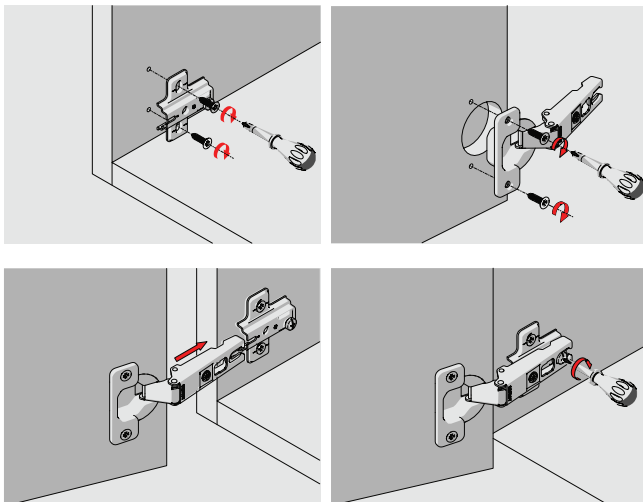

0 mm CRANK	DEFINITION	AXIS	MOUNTING PLATE	FINISH	BAG	PACKAGE
101711388	STAR SELF CLOSE HINGE	52 mm	2 HOLE	NICKEL	2 SETS	80 BAGS

0 mm CRANK	DEFINITION	AXIS	MOUNTING PLATE	FINISH	BAG	PACKAGE
101712388	STAR SELF CLOSE HINGE	52 mm	2 HOLE	NICKEL	2 SETS	80 BAGS

0 mm CRANK	DEFINITION	AXIS	MOUNTING PLATE	FINISH	BAG	PACKAGE
101713388	STAR SELF CLOSE HINGE	52 mm	2 HOLE	NICKEL	2 SETS	80 BAGS